

Rackliff Subdivision

Rackliff Weber County, Utah

A Part of the Northeast Quarter of Section 29,
Township 6 North, Range 2 West, Salt Lake Base & Meridian

SURVEYOR'S CERTIFICATE

I, K. Greg Hansen, do hereby certify that I am a Registered Professional Land Surveyor in the State of Utah in accordance with Title 58, Chapter 22, Professional Engineers and Land Surveyors Act; and I have completed a Survey of the property described on this plat in accordance with Section 17-23-17 and have verified all measurements, and have placed monuments as represented on this plat, and have hereby Amended and Subdivided said tract into three (3) lots, known hereafter as Rackliff Subdivision in Weber County, Utah, and has been correctly drawn to the designated scale and is true and correct representation of the herein described lands included in said Subdivision, based upon data compiled from records in the Weber County Recorder's Office and from said survey made by me or under my supervision on the ground, I further hereby certify that the requirements of all applicable statutes and ordinances of Weber County Concerning Zoning Requirements regarding lot measurements have been complied with.

Signed this _____ day of _____, 2017.

K. Greg Hansen P.L.S.
Utah Land Surveyor Licence No. 167819



BOUNDARY DESCRIPTION

A PART OF THE NORTHEAST QUARTER OF SECTION 29, TOWNSHIP 6 NORTH, RANGE 2 WEST OF THE SALT LAKE BASE AND MERIDIAN.

BEGINNING AT A POINT ON THE SOUTH RIGHT-OF-WAY LINE OF 1800 SOUTH STREET LOCATED 660.01 FEET NORTH 89°02'03" WEST ALONG THE NORTH LINE OF SAID NORTHEAST QUARTER AND 33.00 FEET SOUTH 00°57'57" WEST FROM THE NORTHEAST CORNER OF SAID SECTION 29;

RUNNING THENCE SOUTH 00°48'45" WEST 632.31 FEET TO THE NORTH BOUNDARY LINE OF THE WEBER SCHOOL DISTRICT PROPERTY FILED AS ENTRY NO. 2545667 IN THE FILES OF THE WEBER COUNTY RECORDER; THENCE NORTH 89°04'32" WEST 170.00 FEET ALONG SAID NORTH BOUNDARY LINE; THENCE NORTH 00°48'45" EAST 376.20 FEET TO A POINT ON THE SOUTH BOUNDARY LINE OF DAY'S END SUBDIVISION FILED AS ENTRY NO. 1293025 IN THE FILES OF THE WEBER COUNTY RECORDER; THENCE ALONG THE BOUNDARY LINE OF SAID DAY'S END SUBDIVISION THE FOLLOWING THREE COURSES; (1) NORTH 89°02'03" WEST 164.09 FEET; (2) NORTH 00°42'50" EAST 251.77 FEET TO THE SOUTH RIGHT-OF-WAY LINE OF 1800 SOUTH STREET; AND (3) SOUTH 88°54'40" EAST 164.53 FEET; THENCE NORTH 00°48'45" EAST 4.82 FEET; THENCE SOUTH 89°02'03" EAST 170.00 FEET TO THE POINT OF BEGINNING. CONTAINING 3.417 ACRES.

OWNER'S DEDICATION AND CERTIFICATION

Know all men by these presents that we, the undersigned Owners of the above described tract of land having caused the same to be subdivided into lots and streets, as shown on this plat and name said Rackliff Subdivision and hereby dedicate, grant and convey, in perpetuity, pursuant to the provisions of 17-27a-607, Utah code, without condition, restriction or reservation to Weber County, Utah, all those parts or portions of said tract of land designated as streets the same to be used as public thoroughfares forever, and also dedicate to Weber County those certain strips as easements for public utility and drainage purposes as shown hereon. The same to be used for the installation, maintenance and operation of public utility service lines and drainage as may be authorized by the governing Authority in witness we have here unto set our signature this _____ day of _____, 2017.

Marjorie R. Day Michael Joseph Day
Trustees of the Marjorie R. Day Irrevocable Trust dated January 26, 2016.

Daniel Rackliff Remedios Rackliff

TRUST ACKNOWLEDGMENT

State of Utah
County of Weber

On this _____ day of _____, 2017, Marjorie R. Day and Michael Joseph Day, Trustees of the Marjorie R. Day Irrevocable Trust dated January 26, 2016, personally appeared before me, the undersigned notary public in and for said county of Weber, in the state of Utah, the signers of the attached owners dedication, two in number, who duly acknowledged to me they signed it freely and voluntarily and for the purpose therein mentioned on behalf of said trust.

Notary public

ACKNOWLEDGMENT

State of Utah
County of Weber

On this _____ day of _____, 2017, Daniel Rackliff and Remedios Rackliff, Husband and Wife as Joint Tenants, personally appeared before me, the undersigned Notary Public in and for said County of Weber, in the State of Utah, the signers of the attached Owners Dedication, two in number, who duly acknowledged to me they signed it freely and voluntarily and for the purpose therein mentioned.

Notary Public

WEBER COUNTY RECORDER

ENTRY NO. _____ FEE PAID _____
FILED FOR RECORD AND

RECORDED _____
IN BOOK _____ OF OFFICIAL

RECORDS, PAGE _____ RECORDED
FOR _____

COUNTY RECORDER

BY: _____
DEPUTY

North Quarter Corner of Sec. 29,
T. 6 N., R. 2 W., S.L.B.&M.
Found Weber Co. Survey 3"
Brass Cap Monument dated
1963 in fair condition.

Northeast Corner of Sec. 29,
T. 6 N., R. 2 W., S.L.B.&M.
Found Weber Co. Survey 3"
Brass Cap Monument dated
2004 in good condition.

- PLAT NOTES:
- ALL PUBLIC UTILITY EASEMENTS (PUE'S) ARE 10.00 FEET WIDE UNLESS NOTED OTHERWISE.
 - THE VERTICAL DATUM IS NAVD 88.
 - ALL CONSTRUCTION TO COMPLY WITH WEBER COUNTY CONSTRUCTION STANDARDS AND SPECIFICATIONS.
 - DUE TO THE TOPOGRAPHY AND THE LOCATION OF THIS SUBDIVISION ALL OWNERS WILL ACCEPT RESPONSIBILITY FOR ANY STORM WATER RUNOFF FROM THE ROADS ADJACENT TO THESE PROPERTIES UNTIL CURBS AND GUTTERS ARE INSTALLED.
 - LOTS WILL BE SERVED BY INDIVIDUAL WASTEWATER SYSTEMS. NOTE THAT SUCH SYSTEMS MUST BE A MINIMUM OF 100' FROM WELLS.
 - LOTS WILL BE SERVED BY TAYLOR WEST WEBER WATER.
 - CONSTRUCTION ACTIVITY PERMITS WILL BE REQUIRED FOR ANY CONSTRUCTION THAT:
 - DISTURBS MORE THAN 5000 SQUARE FEET OF LAND SURFACE AREA, OR
 - CONSIST OF THE EXCAVATION AND/OR FILL OF MORE THAN 200 CUBIC YARDS OF MATERIAL, OR
 - REQUIRES A BUILDING PERMIT FOR WHICH EXCAVATION OR FILL IS A PART OF THE CONSTRUCTION, AND LESS THAN ONE ACRE IF PART OF A COMMON PLAN OF DEVELOPMENT.
 - THE PRIVATE LANE ACCESSING LOT 3 IS TO BE CONSTRUCTED AT A MINIMUM WIDTH OF 12' AND BE CAPABLE OF SUPPORTING A 75,000 LB. LOAD.
 - LOT 3 SHALL CONSTRUCT A TURN-AROUND WITH A MAXIMUM INSIDE TURNING RADIUS OF 30' AND A MINIMUM OUTSIDE TURNING RADIUS OF 45'.

AGRICULTURAL NOTE

Agriculture is the preferred use in the Agriculture Zones. Agriculture operations as specified in the zoning ordinance for a particular zone are permitted at any time including the operation of farm machinery and no allowed agriculture use shall be subject to restriction on that it interferes with activities of future residents of this subdivision

LEGEND

- Subject Property Line
- Interior Lot Lines
- Adjoining Property Line
- Previous Property Line
- Centerline
- Public Utility Easement (PUE)
- Ditch
- Field Separation Line
- Fence Line (Wire)
- Existing 6" Waterline
- Fire Hydrant
- Power Pole
- Street Monument
- Found rebar set by others
- Set 5/8"x24" Rebar With Cap
- Section Corner

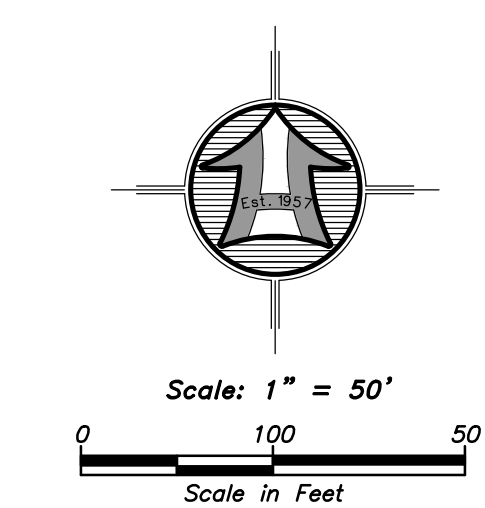
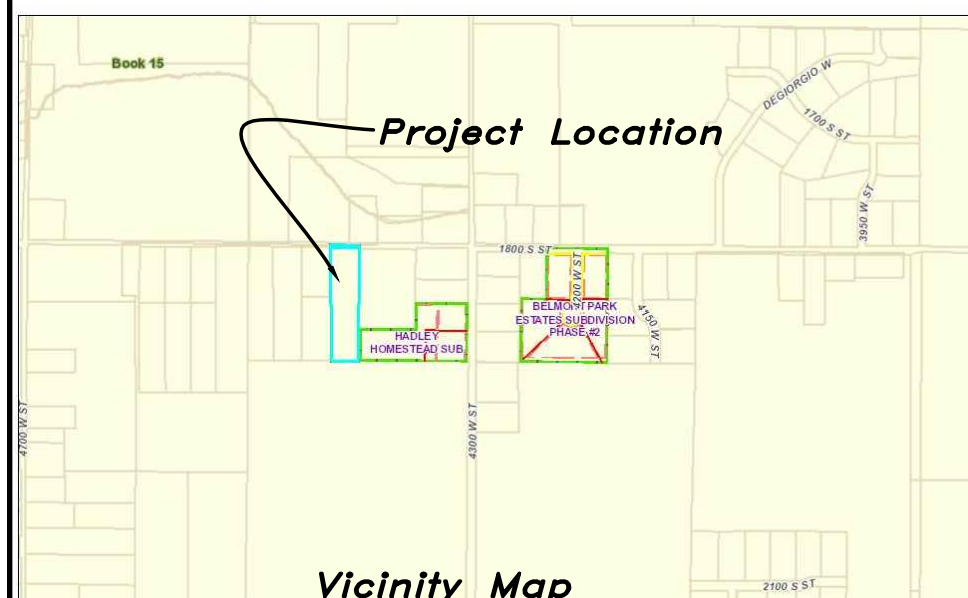

WEBER COUNTY ENGINEER

I hereby Certify that the Required Public Improvement Standards and Drawings for this Subdivision Conform with the County Standards and the Amount of the Financial Guarantee is Sufficient for the Installation of these Improvements.
Signed this _____ Day of _____, 2017.

Weber County Engineer

WEBER COUNTY SURVEYOR

I hereby Certify that the Weber County Surveyor's Office has Reviewed this Plat for Mathematical Correctness, Section Corner Data, and for Harmony with the Lines and Monuments on Record in County Offices. The Approval of this Plat by the Weber County Surveyor does not Relieve the Licensed Land Surveyor who Executed this Plat from the Responsibilities and/or Liabilities Associated Therewith. Signed this _____ Day of _____, 2017.

Weber County Surveyor

NARRATIVE

The purpose of this survey was to establish and set the property corners of the three lot subdivision as shown and described hereon. This survey was ordered by Remedios Rackliff. The west boundary of the Rackliff property conflicts with the east boundary line of the original Days End Subdivision owned by Marjorie R. Day. Day Quit Claimed, Entry No. 2859448, the overlap to Quintin Sanders, (the prior owner of the Rackliff property) releasing any interest in the overlapping deeds. This Subdivision is an Amendment of the original Day's End Subdivision to create the new two lots on the Rackliff property and to clear up the overlap mentioned above. The control used to establish the property corners was the existing Weber County Surveyor Monumentation surrounding Section 29, Township 6 North, Range 2 West, S.L.B.&M. The basis of bearing is the North line of the Northeast Quarter of said Section which bears North 89°02'03" West, Utah North, State Plane, Calculated N.A.D.83 Bearing.

WEBER COUNTY PLANNING COMMISSION APPROVAL

This is to Certify that this Subdivision Plat was Duly Approved by the Weber County Planning Commission.
Signed this _____ Day of _____, 2017.

Chairman, Weber County Planning Commission

WEBER-MORGAN HEALTH DEPARTMENT

I hereby Certify that the Soils, Percolation Rates, and Site Conditions for this Subdivision have been Investigated by this Office and are Approved for On-Site Wastewater Disposal Systems.
Signed this _____ Day of _____, 2017.

Weber-Morgan Health Department

Developer: Remedios Day's End 801-564-5672

Notes: 1- ALL PUBLIC UTILITY EASEMENTS (PUE'S) ARE 10.00 FEET WIDE UNLESS NOTED OTHERWISE.

HANSEN & ASSOCIATES, INC.
Consulting Engineers and Land Surveyors
538 North Main Street, Brigham, Utah 84302
Visit us at www.haies.net
Brigham City Ogdan Logan
(435) 723-3491 (801) 399-4905 (435) 752-8272
Celebrating 60 Years of Business