

PROFILE CERTIFICATION

The below profile has been reviewed. As the purchaser or representative of the purchaser, it is certified:

1. The location of the terminals, towers, loading and unloading points are acceptable and the clearances under the lift are adequate.
2. The following elevations have been verified.
Bottom terminal load surface elev. - 6534.00 ft.
Top terminal unload surface elev. - 7929.00 ft.
Top terminal toe of ramp (grade) elev. - A/R ft.
3. All grading will be completed as shown.

It is herewith understood that final drawings will be prepared based upon this profile and if any changes are made after certification of this profile all engineering costs will be borne by the purchaser and due upon acceptance of the drawings.

BY: _____ DATE: _____
Purchaser

Title

Company

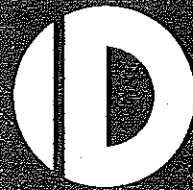

Profile

6-CLD Wildcat

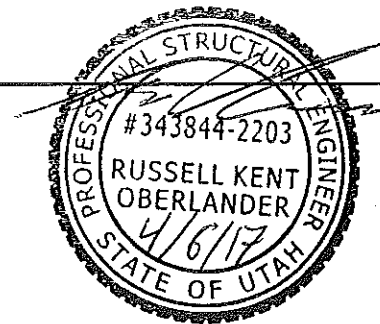

Customer: Snowbasin

Location: Utah

Technical Data:

Uphill Side	Right	Ø Haul Rope	1.69 in
Drive Station	Top	Minimum Breaking Strength	290678 lb
Tension Station	Bottom	Ø Drive Bullwheel	18.04 ft
Return Station	Bottom	Ø Return Bullwheel	18.37 ft
Horizontal Length	4832.08 ft	Rope Gauge on Line	18.37 ft
Vertical Rise	1395.01 ft	Drive Output Continuous	514 HP
Average Grade	28.87 %	Drive Output Starting	0 HP
Max. Rope Inclination	58.14 %	Elevation of Drive Station	7940 ft
Inclined Length	5055.76 ft	Uphill Transportation	100 %
Spliced Rope Length	10284.63 ft	Downhill Transportation	25 %

	Initial	Final
Drive Speed	1000 fpm	1000 fpm
Capacity	2320 pph	2400 pph
Number of Carriers	69	71
Carrier Spacing	155.17 ft	150.00 ft
Carrier Interval	9.31 s	9.00 s
Trip Time	5.40 min	5.40 min

b	Moved towers 3, 4 & 5.	2017-03-20	DBR
a	New survey, complete revision.	2017-03-07	DBR
Index	Revision	Date	Name

	3160 West 500 South Salt Lake City, Utah 84104	Scale	Project No.
		1"=40'	SAA0002518
		Drawing No.	Index
		SAA0002518-PROF	

This drawing is the intellectual property of Doppelmayr USA, Inc. It must not be copied nor utilized in whole or in part without permission and is subject to return upon request.

7940.49

Profile origin:
 Profile file: SAA0002518r02 Snowbasin Wildcat.gel
 Ropeway file: SAA0002518r03 Snowbasin Wildcat.cid
 Program: Selba 1.56.3 CIN:1490917439

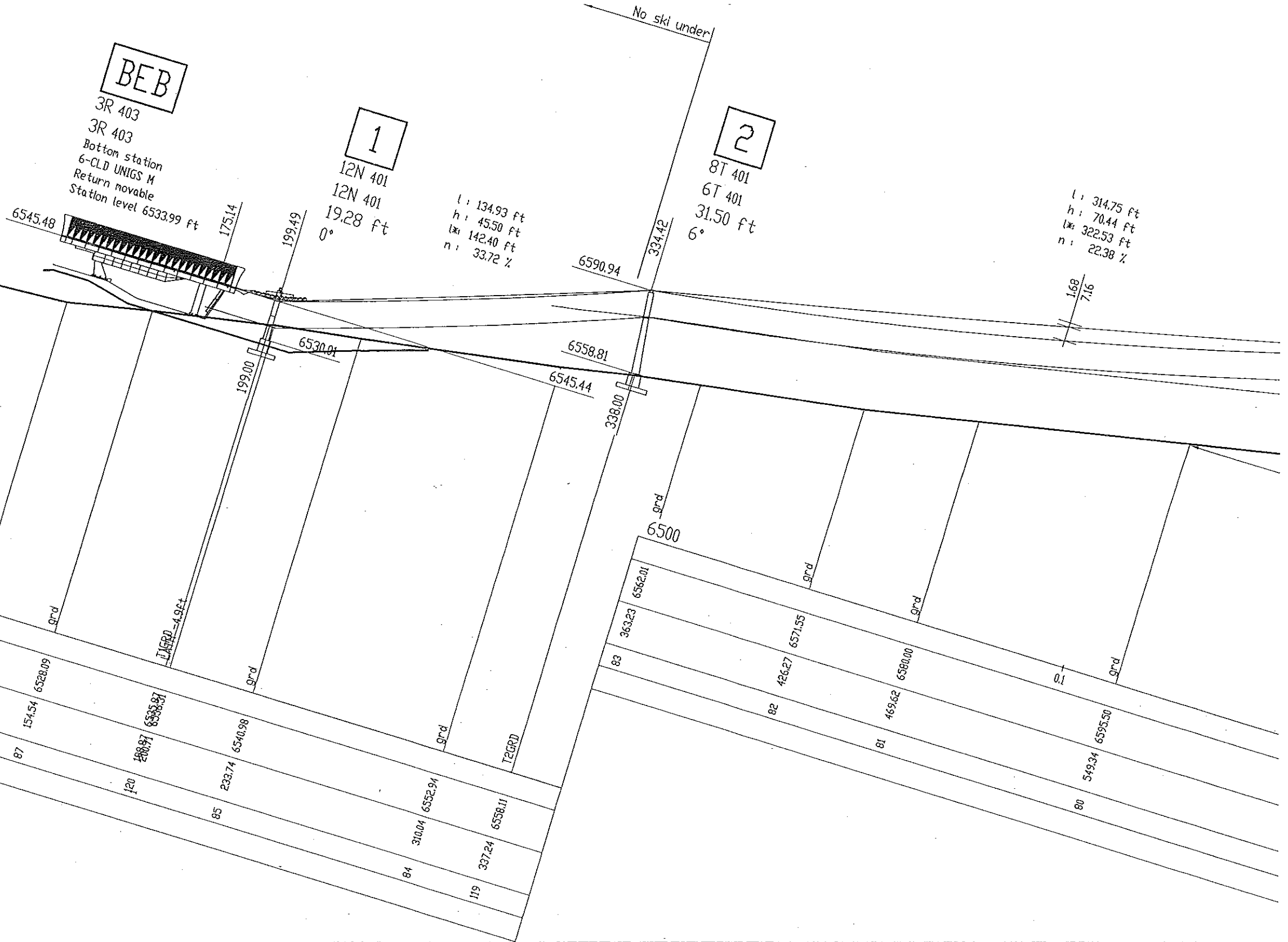

Vertical [ft]
 Horizontal [ft]
 Point No
 Cross slope [%] right

88	82.97	6519.65	6400
121	122.25	6521.68	GRD
87	154.54	6528.09	GRD
120	288.97	6533.87	GRD
85	233.74	6540.98	GRD
84	310.04	6552.94	GRD
119	337.24	6558.11	GRD
83	363.23	6562.01	GRD
82	426.27	6571.55	GRD
81	469.62	6580.00	GRD
80	549.34	6595.50	GRD

3

6T 401
6T 401
44.50 ft
6°

l: 346.19 ft
h: 72.40 ft
w: 353.68 ft
n: 20.91 %

4

4T 401
4T 401
42.70 ft
6°

l: 278.49 ft
h: 66.76 ft
w: 286.38 ft
n: 23.97 %

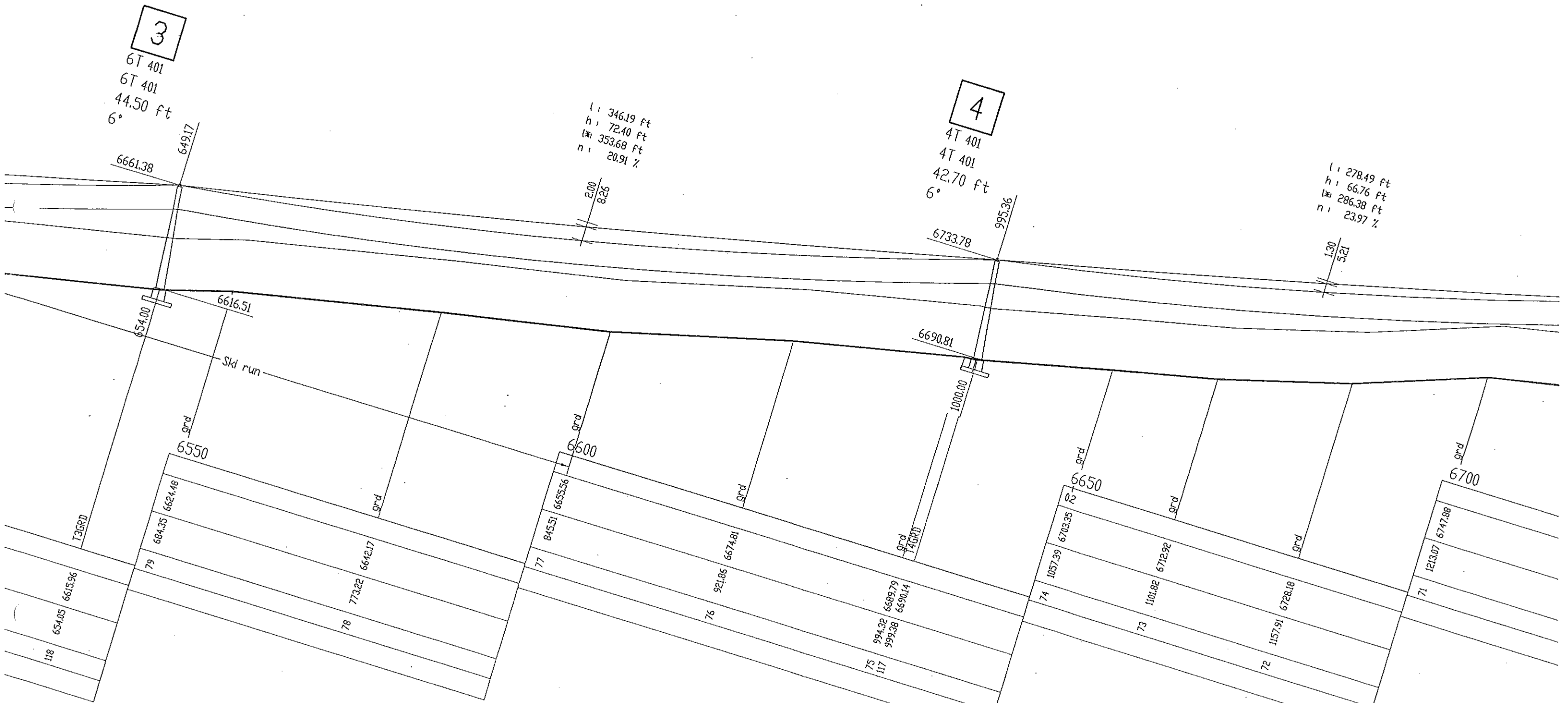

2.00
82.6

1.30
52.1

6616.51

6690.81

6550

6600

6650

6700

Ski run

13GRD

74GRD

grd

grd

79

78

77

76

75

74

73

72

71

684.35

6624.18

773.22

6642.17

845.51

6655.56

921.86

6674.81

994.32

6689.79

999.38

6690.14

1057.39

6703.35

1101.82

6712.92

1157.91

6728.18

1213.07

6747.88

118

654.05

6615.96

6661.38

649.17

654.00

6733.78

995.36

1000.00

MINIMUM CLEARANCE WITH SIDE SLOPE

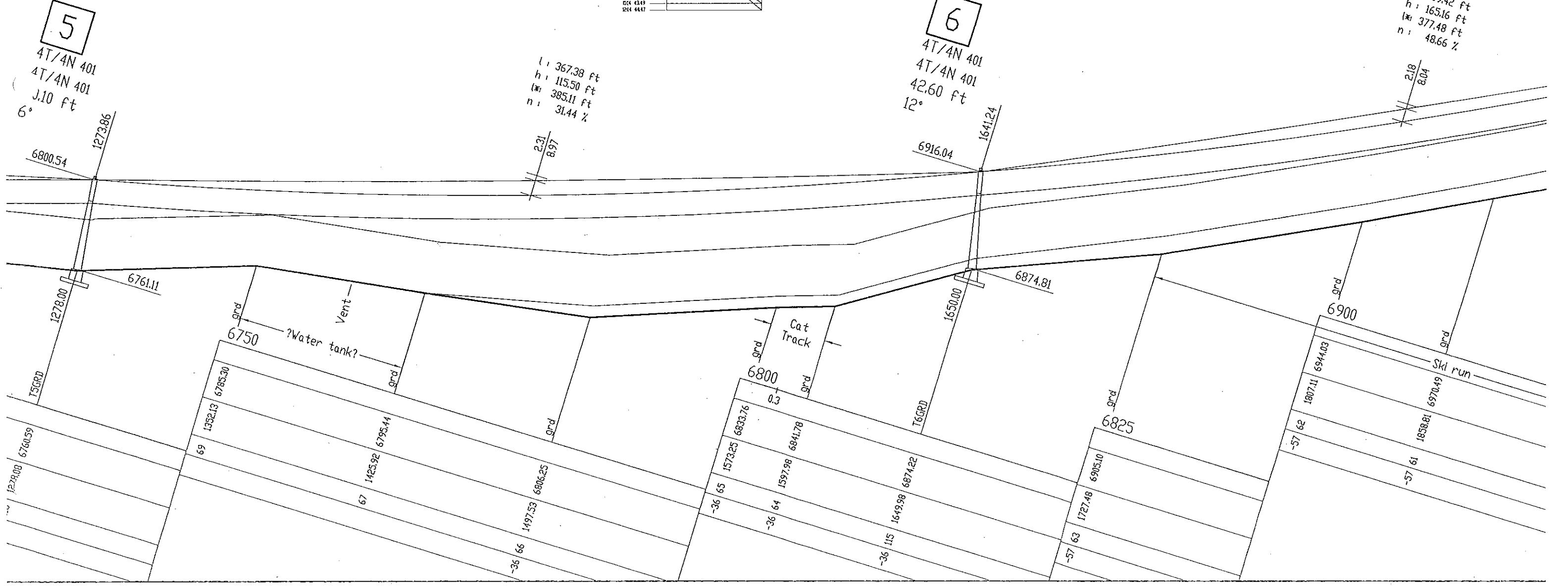
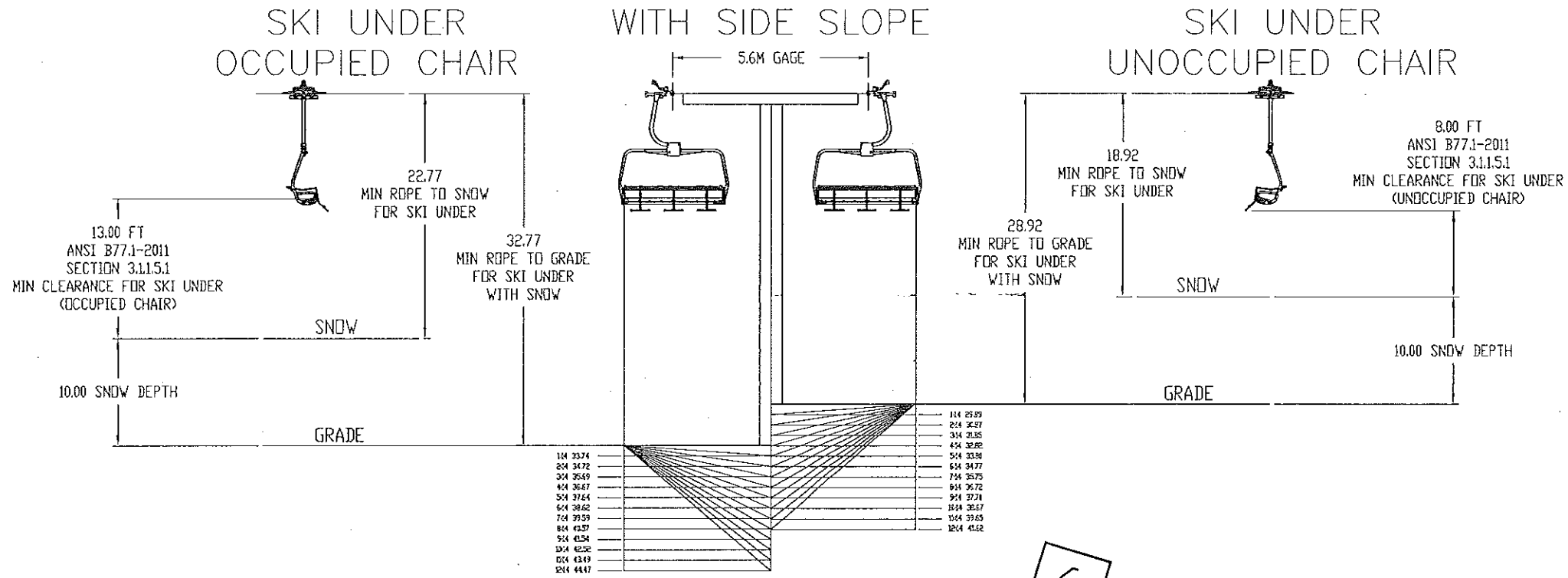

9

8T 401
6T 401
43.80 ft
12°
7290.44
2535.66

l: 409.32 ft.
h: 111.36 ft
w: 424.20 ft
n: 27.21 %

2.62
8.68

10

4T/4N 401
4T/4N 401
48.70 ft
12°
7401.80
2944.98

l: 338.83 ft
h: 142.19 ft
w: 367.46 ft
n: 41.97 %

1.93
6.19

7246.91
2545.00
7200
-57 45 2660.57 7273.97
-43 44 2736.73 7291.13
-43 43 2845.15 7319.08
-43 42 2935.23 7354.18
7367 7234.53
0.5

Ski run

7354.61

7300

41 3018.57 7375.50

10 3066.55 7396.57

39 3114.08 7424.49

38 3170.57 7455.24

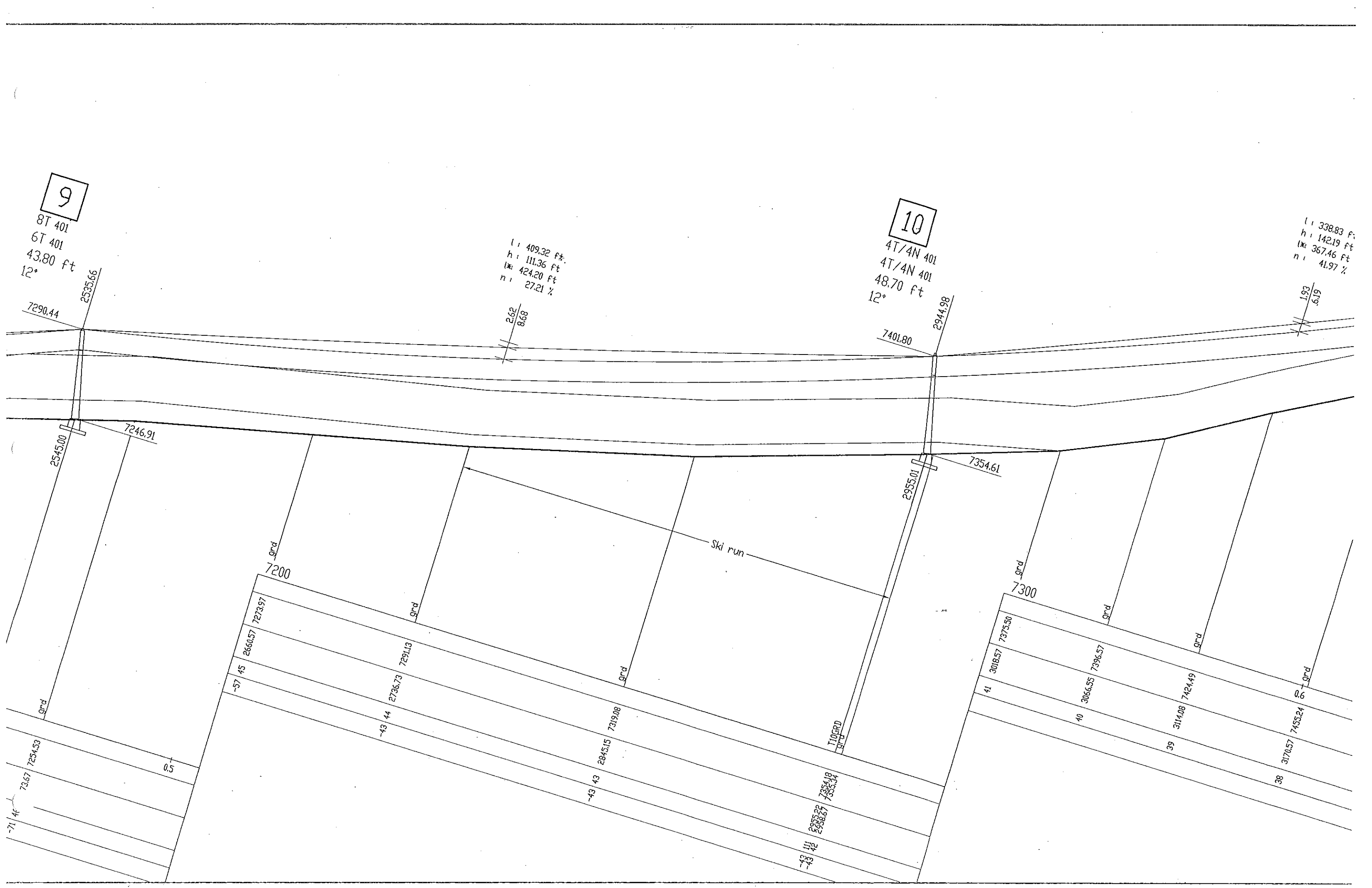

11

6T 401
4T 401
33.20 ft
12°

7543.99
3291.01
3283.81

l: 286.86 ft
h: 113.08 ft
w: 308.35 ft
n: 39.42 %

1.34
4.15

12

8T 401
6T 401
48.15 ft
12°

7657.07
3570.67

l: 208.66 ft
h: 61.03 ft
w: 217.40 ft
n: 29.25 %

0.66
2.00

7718.10

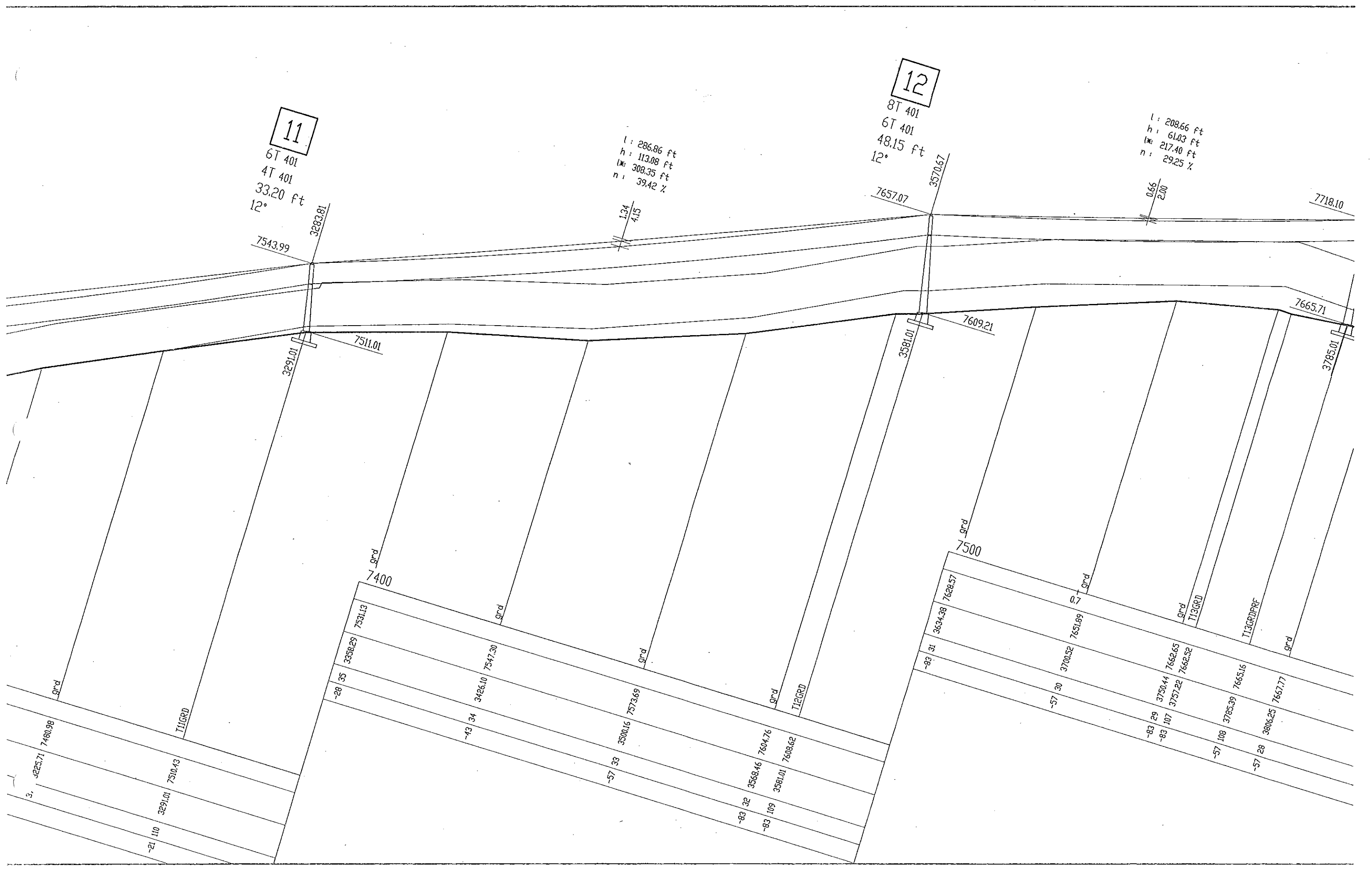

3225.71 7480.98

-21 110 3291.01 7510.43

-28 35 3358.29 7531.13

-43 34 3426.10 7547.30

-57 33 3500.16 7573.69

-83 32 3568.46 7604.76
-83 109 3581.01 7608.62

-83 31 3634.38 7628.57

-57 30 3700.52 7651.89

-83 29 3750.44 7662.65
-83 107 3757.22 7662.52

-57 108 3785.39 7665.16

-57 28 3806.25 7667.77

7665.71

3785.01

7500

7628.57

7651.89

7662.65

7665.16

7667.77

Rd 7400

Rd 7500

T11GRD

T12GRD

T13GRD

T13GRDPRF

Grd

Grd

Grd

Grd

Grd

Grd

Grd

Rd

Rd

13

8T 401
6T 401
52.00 ft
6°

3779.33

Horizontal Length l : 560.74 ft
Vertical Rise h : 144.49 ft
Inclined Length l_s : 579.05 ft
Average Grade n : 25.77 %

4.60 ft min. Sag
13.64 ft max. Sag

14

Sheaves Up 8T 401
Sheaves Down 6T 401
Tube length 44.95 ft
Tube Angle 6°

4340.07

7862.59

7817.21

4345.01

Ski run

560
7600

-38 206 4007.78 7711.28

-36 24 4089.90 7735.66

-36 23 4155.02 7757.73

-43 22 4222.29 7778.76

7700

-57 21 4306.53 7803.74

-57 105 4345.00 7816.69

-57 20 4373.71 7826.83

104 4458.08 7830.08

-57 21 3870.60 7676.12

-43 26 3939.42 7691.51

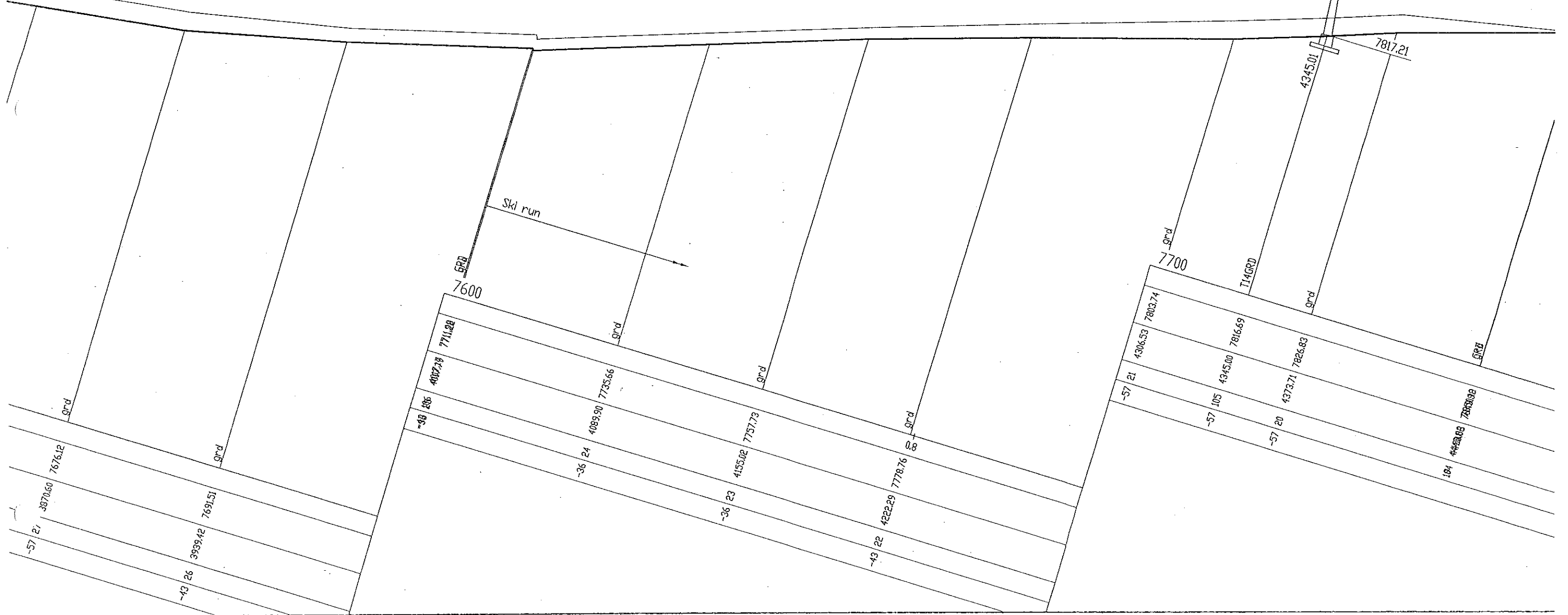

l: 234.73 ft
h: 52.65 ft
w: 240.56 ft
n: 22.43 %

0.78
2.27

15

8T 401
6T 401
37.70 ft
0°

7915.24
4574.79

l: 125.13 ft
h: 15.59 ft
w: 126.10 ft
n: 12.46 %

16

8T 401
6T 401
34.50 ft
0°

7930.83
4699.92

l: 266.06 ft
h: 9.46 ft
w: 266.23 ft
n: 3.56 %

0.95
2.72

17

4T 401
4T 401
29.95 ft
0°

7940.29
4965.98

No ski under

TEB

3R 403
3R 403
Top station
6-CLD UNIGS S
Drive fixed
Station level 7929.00 ft

5007.23

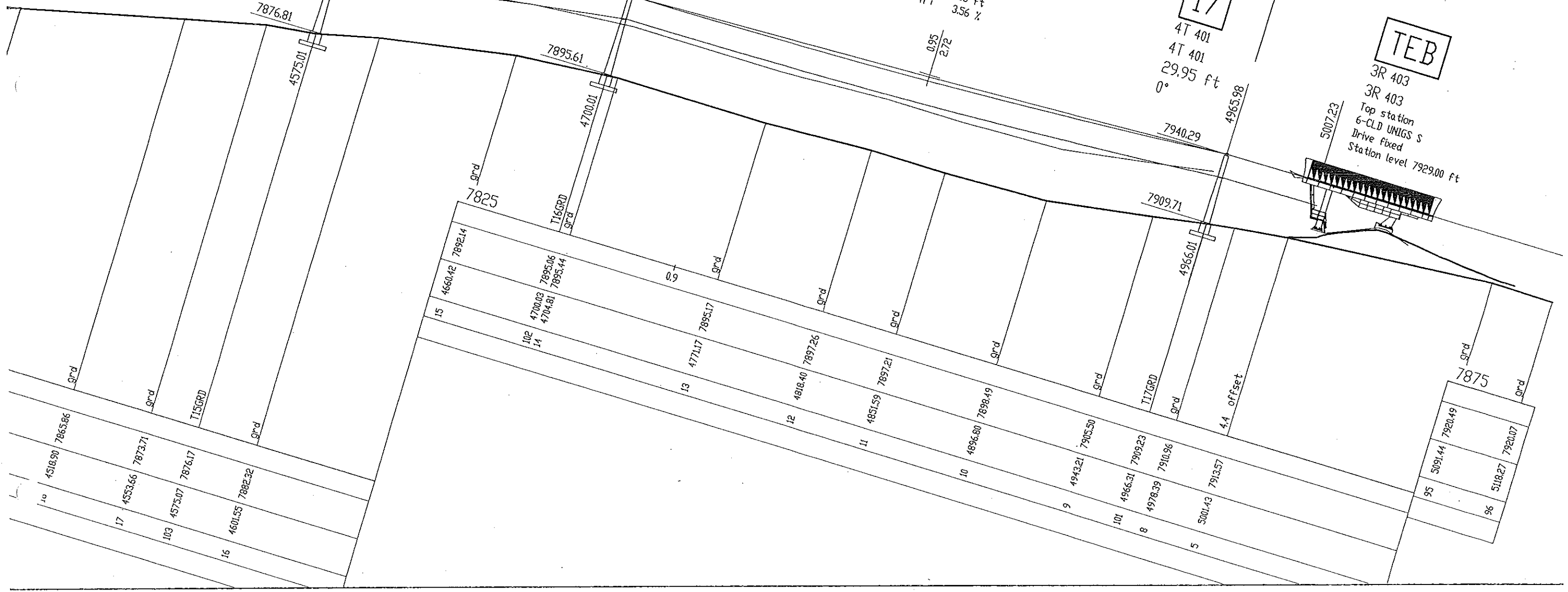
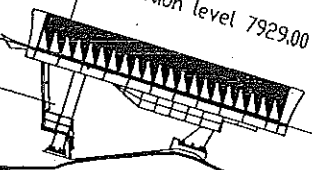

10 4518.90 7865.86
17 4553.66 7873.71
103 4575.07 7876.17
16 4601.55 7882.32

15 4660.42 7892.14
102 4700.03 7895.06
14 4704.81 7895.44
13 4774.17 7895.17
12 4818.40 7897.26
11 4851.59 7897.21
10 4896.80 7898.49
9 4943.21 7905.50
101 4966.31 7909.23
8 4978.39 7910.96
5 5001.43 7913.57

95 5091.44 7920.49
96 5118.27 7920.07

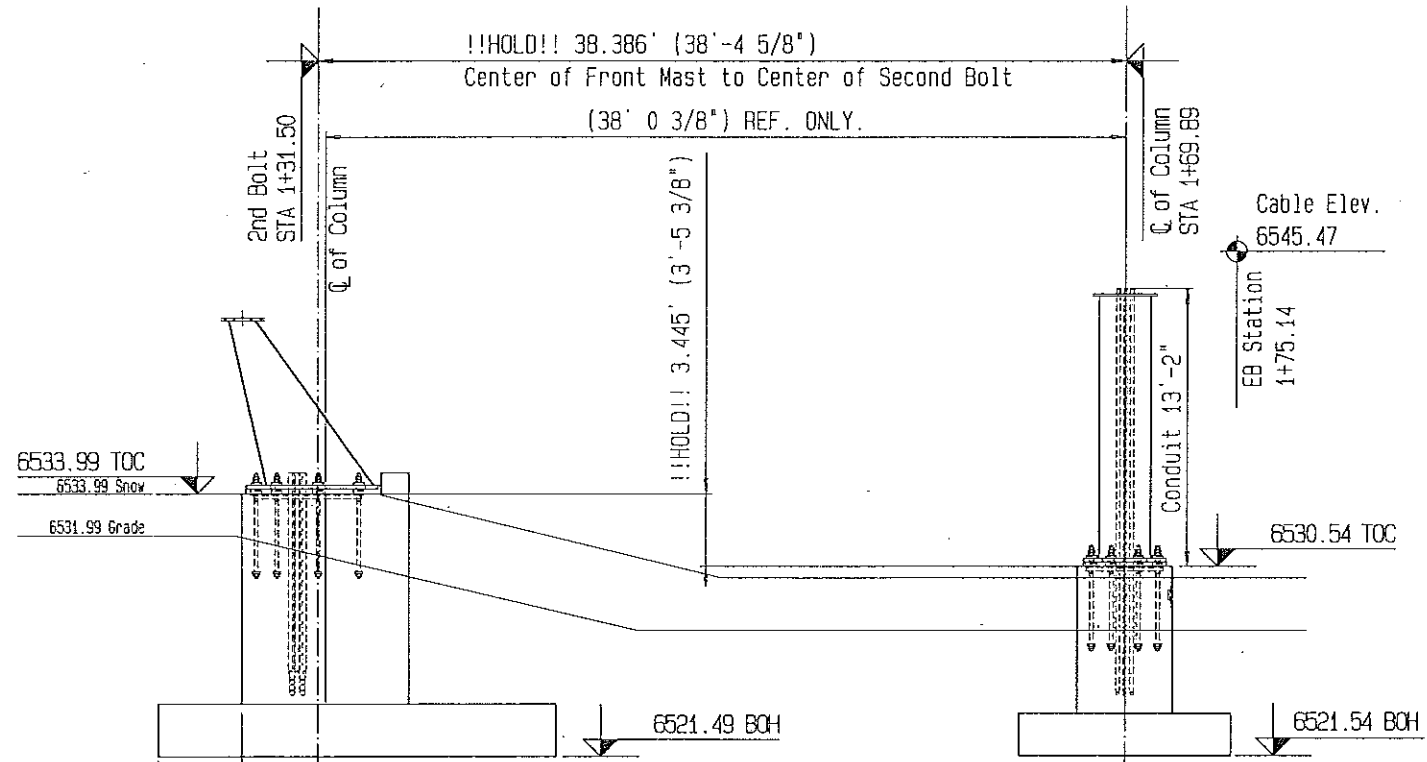

Front Mast Foundation
for Concrete & Rebar see
ID 55051668

Rear Mast Foundation
for Concrete & Rebar see
ID 55051667

DETAIL "14"
S=1:50

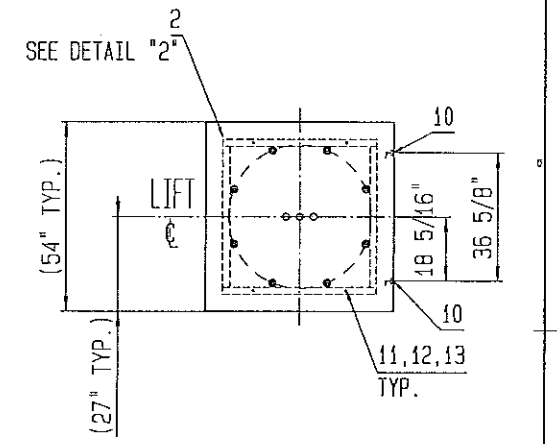
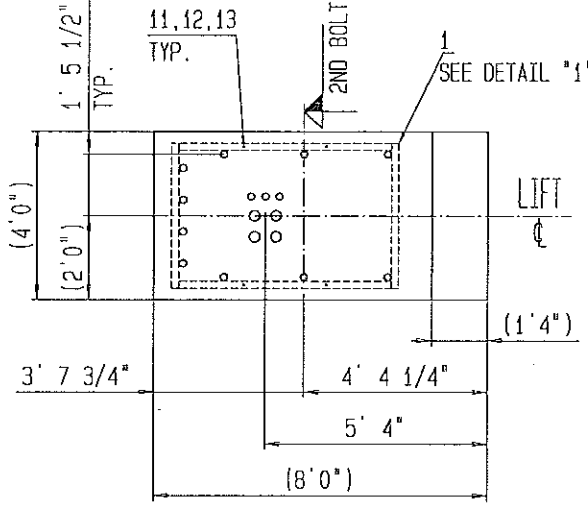
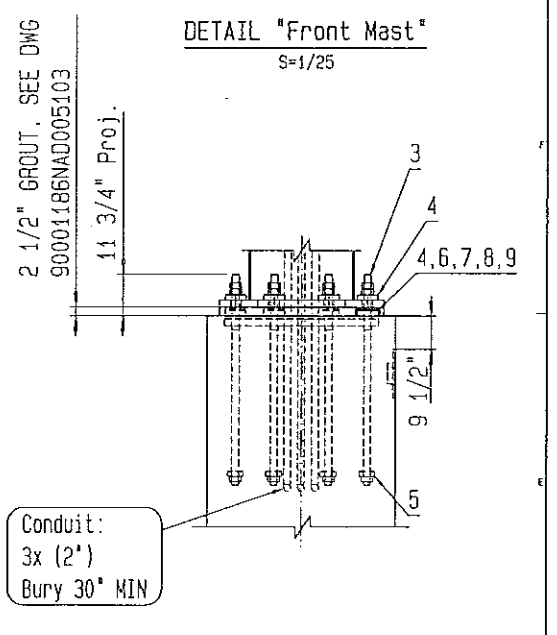
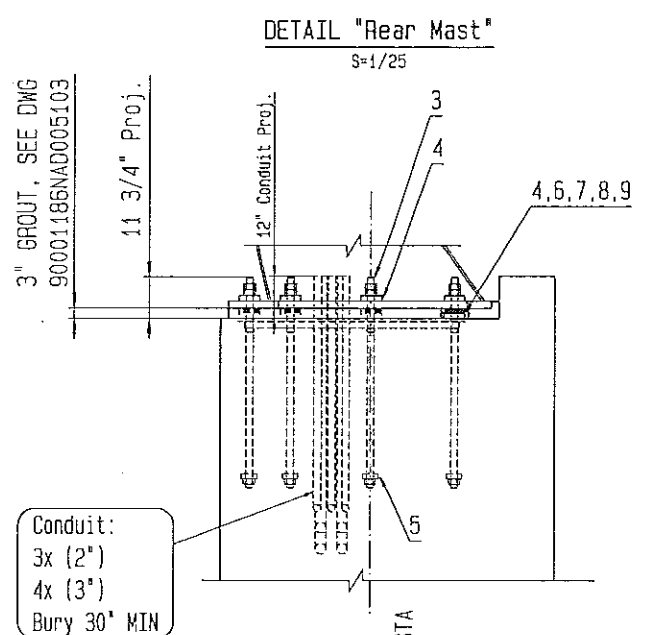
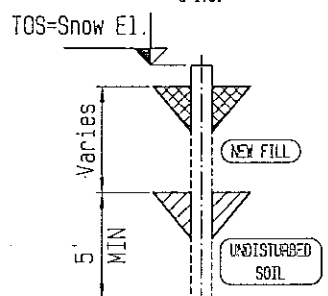

DETAIL "1"
S=1:12.5

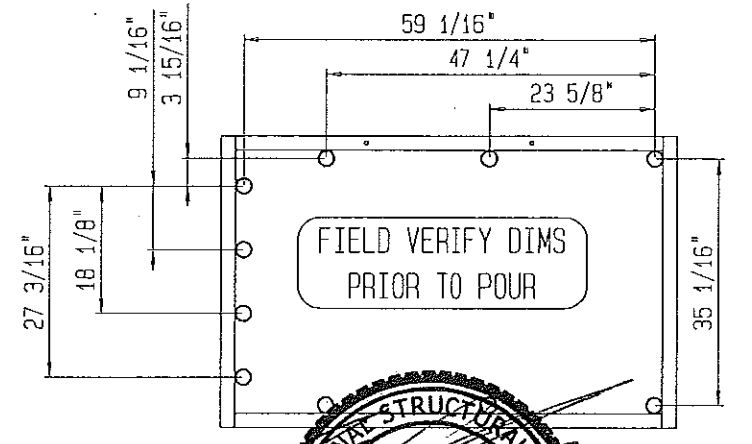

DETAIL "2"
S=1:12.5

FIELD VERIFY DIMS
PRIOR TO POUR

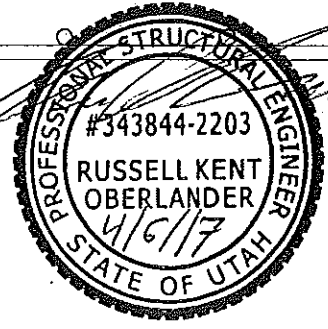
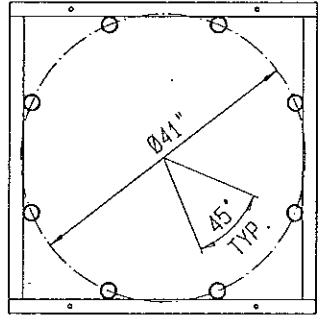

NO.	REVISION	DATE	NAME	DESCRIPTION	SCALE	DATE	NAME
0					1/50	2017-04-07	

CONCRETE PARTS KIT		55051666
ORDER	SAAD00251B	
QUANTITY	1	
UNIT	kg	
PRICE		
TOTAL		

PROJECT	SNOWBASIN / WILOCAT
ORDER	SAAD00251B
RETURN STATION	UNIGS-M 6-OLD
CONTRACT NO.	90007819NAD005100

This drawing is the intellectual property of Doppelmayr USA, Inc. This drawing or information is our property and must not be copied, reproduced, or used in whole or in part without permission and is subject to return upon request.

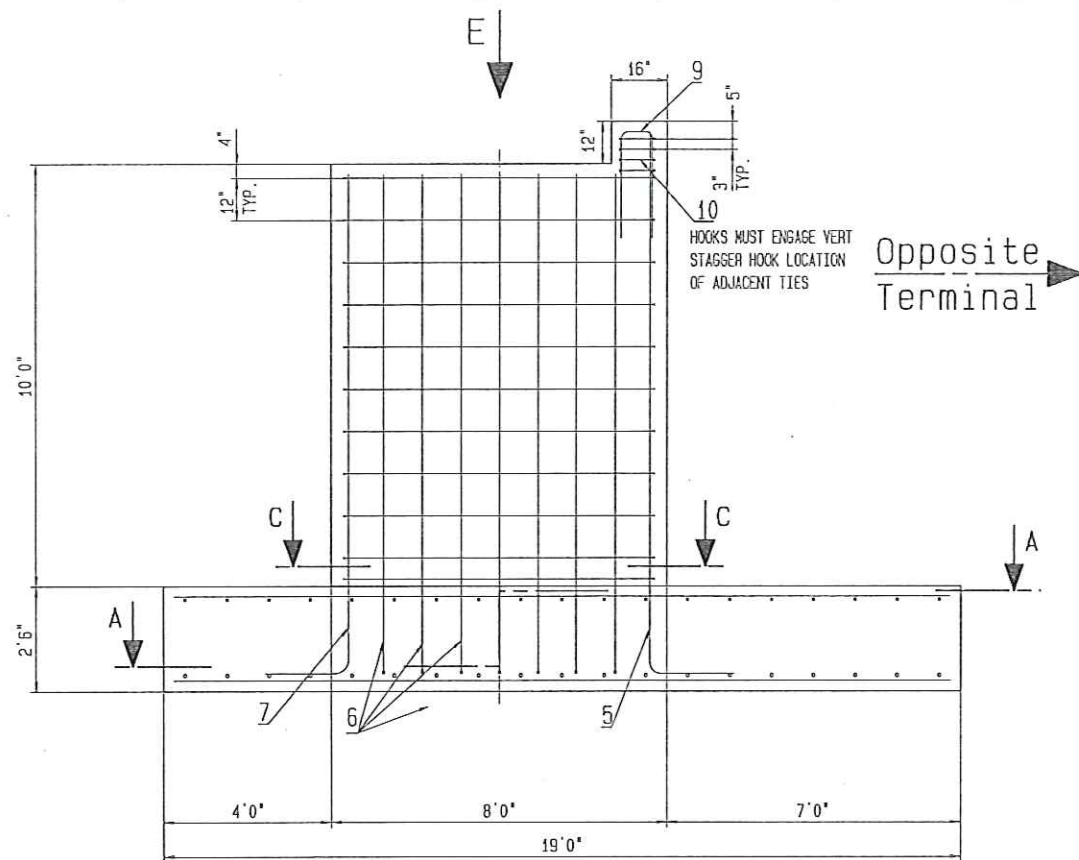

SECTION "A-A"
Ech. 1:25

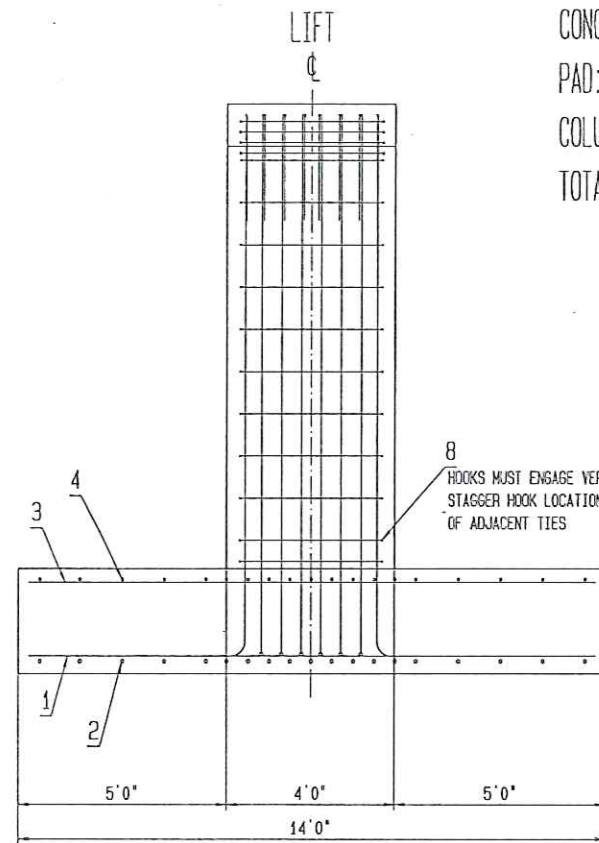
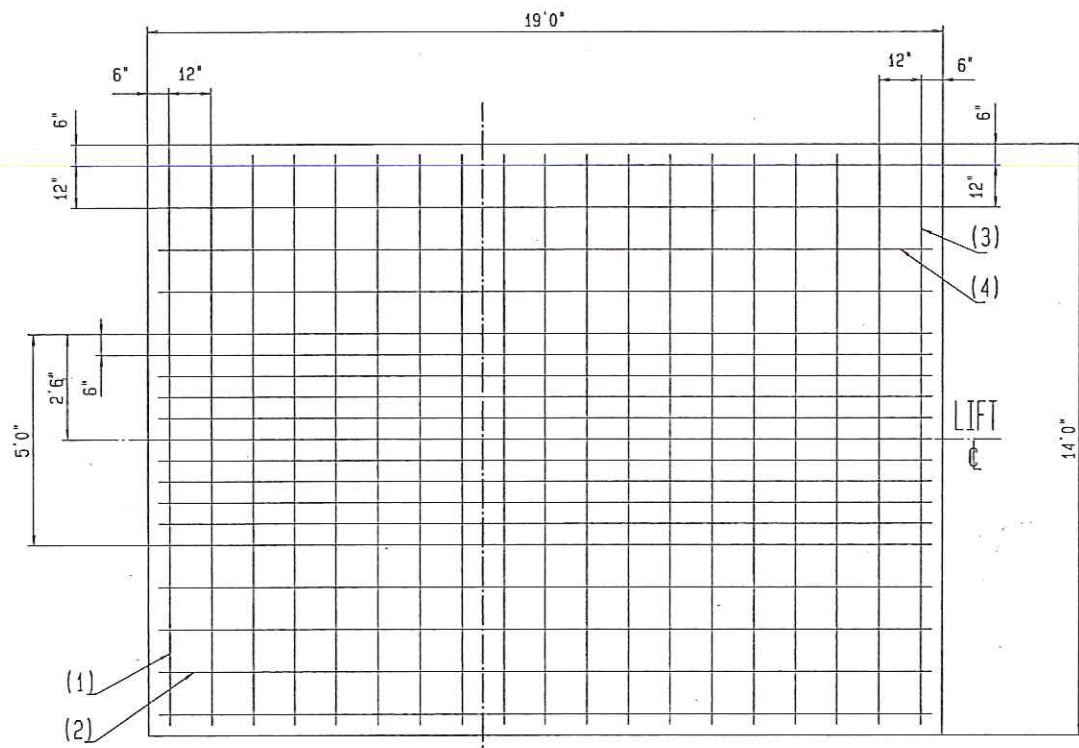

VIEW "E"
Ech. 1:25

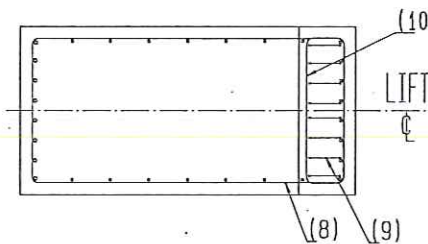

SECTION "C-C"
Ech. 1:25

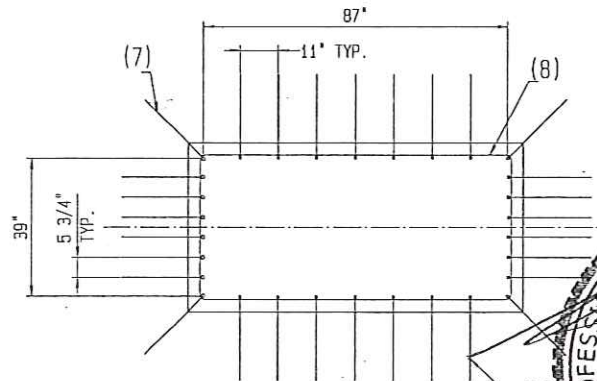

CONCRETE VOLUME :
PAD: 24.6 YDS'3
COLUMN: 12.0 YDS'3
TOTAL: 36.6 YDS'3

NOTES:

- All rebar shall be ASTM A615 (60 KSI) or G400 metric.
- All rebar dimensions shown are out to out.
- All rebar shall be bent in accordance with ACI 318-14.
- All rebar splices shall be in accordance with ACI 318-14.
- For grounding & concrete specifications see 90001186NAD005103.
- Minimum concrete cover = 3".
- Assumed soil pressure = 2800 psf.
- Minimum backfill 8'0".

shape	item	quant	Ø	length
STRAIGHT	1	19	#8	13'6"
STRAIGHT	2	19	#8	18'6"
STRAIGHT	3	19	#4	13'6"
STRAIGHT	4	19	#4	18'6"
24" [13'3"	5	8	#8	15'3"
24" [12'3"	6	14	#8	14'3"
24" [12'3"	7	8	#9	14'3"
41" [89" [1 1/2" [1/2"	8	11	#3	22'2"
9" [30"	9	8	#5	5'9"
10 1/2" [41 1/2" [1 1/2" [1/2"	10	4	#4	9'2"

FOR CONDUIT, ANCHOR BOLT, TEMPLATE, EMBEDS, AND OTHER DETAILS SEE FOUNDATION LAYOUT.

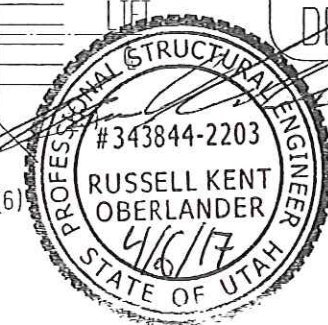

DATE	1/25	SCALE	1/25	DATE	2017-04-07
REVISION	0	PROJECT	SNOWBASIN / WILLOCAT	ORDER	9A0002518
DRAWING NO.			90007820NAD005100		

55051667

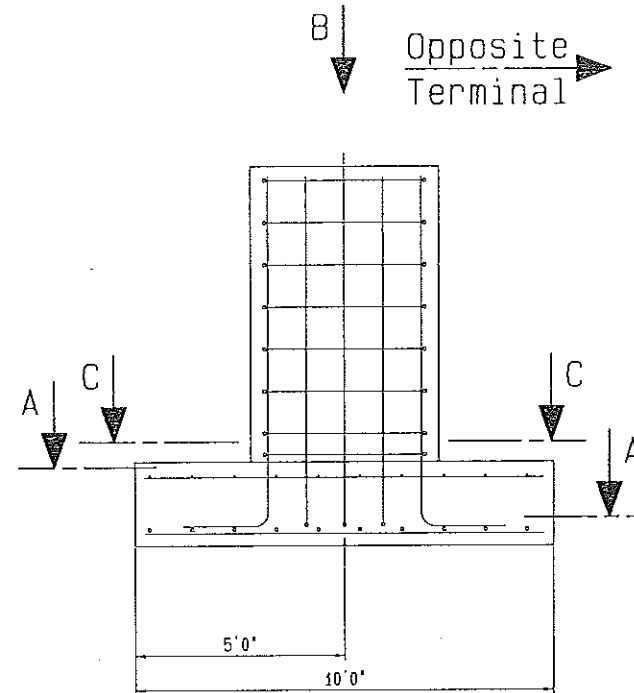

SECTION "A-A"
Ech. 1:25

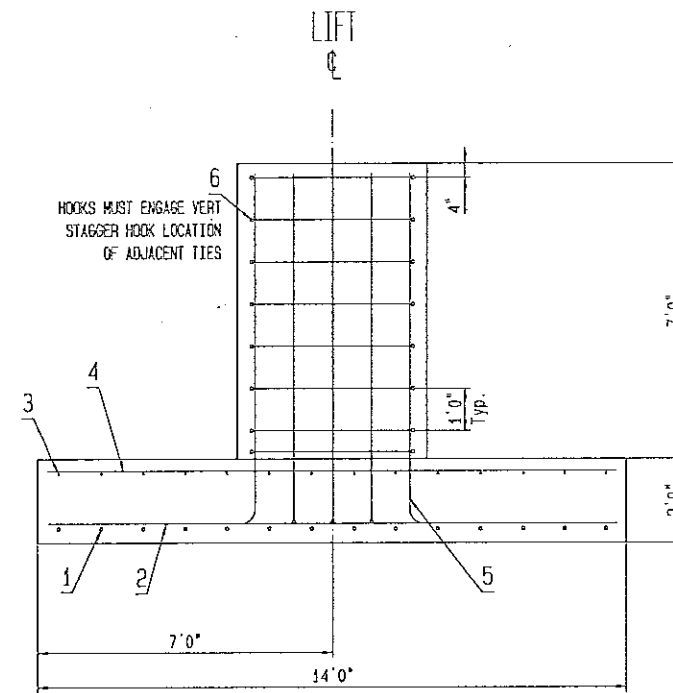

VIEW "B"
Ech. 1:25

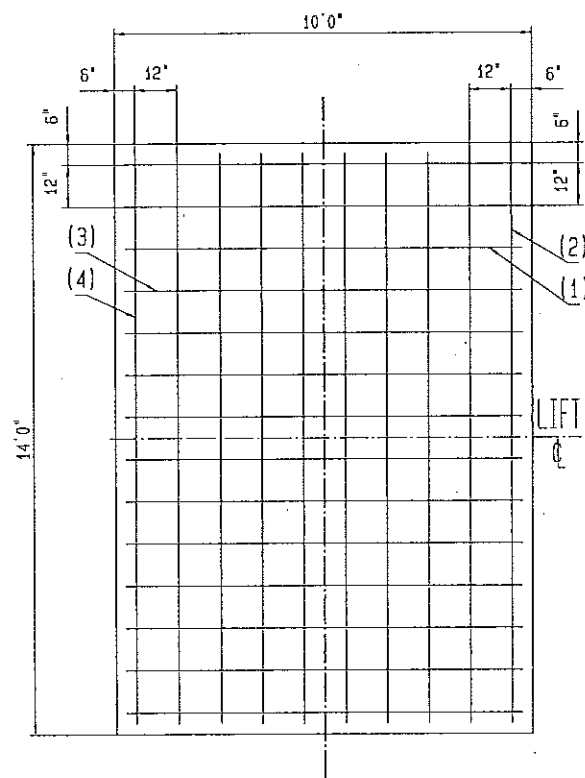

SECTION "C-C"
Ech. 1:25

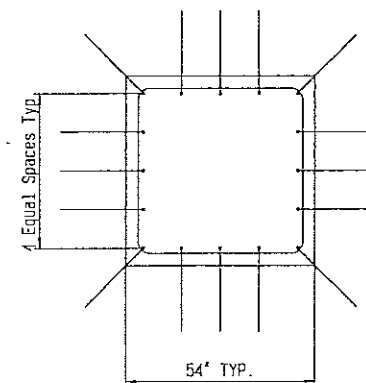
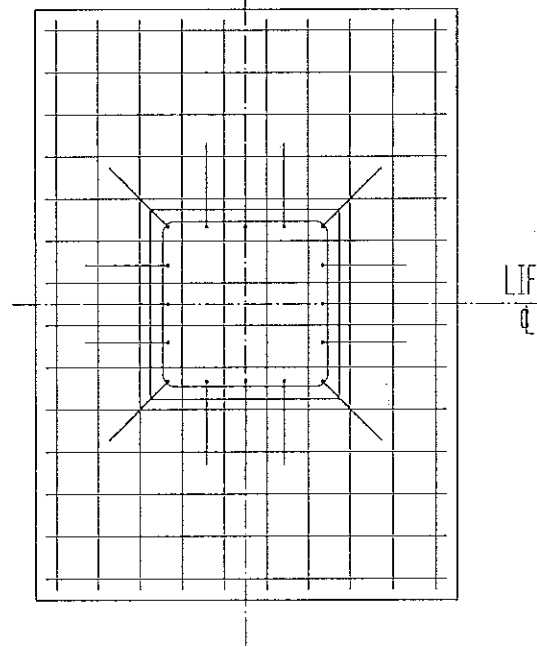

CONCRETE VOLUME :
PAD: 10.4 YDS'3
COLUMN: 5.3 YDS'3
TOTAL: 15.7 YDS'3

NOTES:

- All rebar shall be ASTM A615 (60 KSI) or G400 metric.
- All rebar dimensions shown are out to out.
- All rebar shall be bent in accordance with ACI 318-14.
- All rebar splices shall be in accordance with ACI 318-14.
- For grounding & concrete specifications see 90001186NAD005103.
- Minimum concrete cover = 3".
- Assumed soil pressure = 2800 psf.
- Minimum backfill 4'0".

shape	item	quant	Ø	length
—	1	14	#8	9'6"
—	2	10	#8	13'6"
—	3	14	#4	9'6"
—	4	10	#4	13'6"
24" — 8'9"	5	16	#8	10'9"
47" — 47" 1/8" 1/8"	6	8	#3	16'2"

FOR CONDUIT, ANCHOR BOLT, TEMPLATE, EMBEDS, AND OTHER DETAILS SEE FOUNDATION LAYOUT.

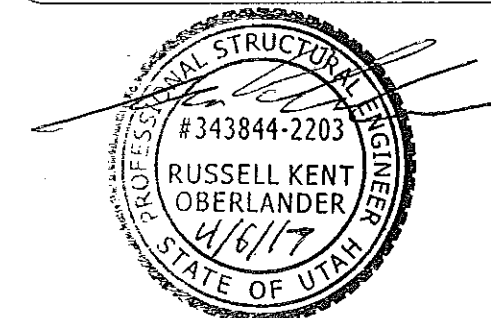

PROJECT	REVISION	DATE	NAME	DESIGNED	SCALE	DATE	NAME
Doppelmayr	0				1/25	2017-04-07	
CLIENT	OPER	PROJECT	SCALE	DATE	NAME	PROJECT	SCALE
SHOMBASIM / WILDCAT	SAA0002519	0725	X	2017-04-07		90007821NAD005100	
FRONT MAST FOUNDATION (BOTTOM)				ITEM NO.			
TENSION STATION				ITEM NO.			
UNIGS-M 6-CLD				ITEM NO.			

55051668

This drawing is intellectual property of Doppelmayr USA, Inc. This drawing or information is our property and must not be copied, reproduced, or used in whole or in part without permission and is subject to future legal action.

DIMENSION "D" MAY BE DECREASED IF FOUNDATION SITE CONDITIONS ALLOW (ENGINEERED FILL OR OTHER) CUT VERTICAL BAR AND MODIFY OTHER ELEMENTS AS NEEDED.

TWR #	FOOTING STATION	FOOTING OFFSET	FOOTING ELEVATION	FOOTING DESCRIPTION	FOOTING ASSEMBLY	A	B	C	D	E	F	CONCRETE REQ'D	PAD STEEL				PEDESTAL STEEL		
													BOTTOM LAYER		TOP LAYER		VERTICAL STEEL		HOOPS
													PAR. TO C (ITEM 1)	PERP. TO C (ITEM 2)	PAR. TO C (ITEM 3)	PERP. TO C (ITEM 4)	(QTY - SIZE)	(LEG 1 X LEG 2)	
P1	1+00.47	15.86	6530.50	24" SQ, 0", 4 BLT	90004948NAD005102 55027756	13' - 6"	5' - 0"	9' - 0"	12' - 0"	1' - 6"	3' - 6"	4.3	5 #8 @ 12" 8' - 6" LONG	9 #6 @ 12" 4' - 6" LONG	5 #3 @ 12" 8' - 6" LONG	9 #3 @ 12" 4' - 6" LONG	8 - #8	13' - 3" X 2' - 0"	24
P2	1+14.93	28.86	6530.50	24" SQ, 0", 4 BLT	90004948NAD005102 55027756	13' - 6"	6' - 0"	11' - 0"	12' - 0"	1' - 6"	3' - 6"	5.5	6 #8 @ 12" 10' - 6" LONG	11 #6 @ 12" 5' - 6" LONG	6 #3 @ 12" 10' - 6" LONG	11 #3 @ 12" 5' - 6" LONG	8 - #8	13' - 3" X 2' - 0"	24
P3	1+31.93	43.30	6530.50	24" SQ, 0", 4 BLT	90004948NAD005102 55027756	11' - 6"	9' - 0"	5' - 0"	10' - 0"	1' - 6"	3' - 6"	4.0	9 #6 @ 12" 4' - 6" LONG	5 #8 @ 12" 8' - 6" LONG	9 #3 @ 12" 4' - 6" LONG	5 #3 @ 12" 8' - 6" LONG	8 - #8	11' - 3" X 2' - 0"	20
P4	1+48.93	43.30	6530.50	24" SQ, 0", 4 BLT	90004948NAD005102 55027756	9' - 6"	9' - 0"	5' - 0"	8' - 0"	1' - 6"	3' - 6"	3.7	9 #6 @ 12" 4' - 6" LONG	5 #8 @ 12" 8' - 6" LONG	9 #3 @ 12" 4' - 6" LONG	5 #3 @ 12" 8' - 6" LONG	8 - #8	9' - 3" X 2' - 0"	16
TOTAL												17.5		84					

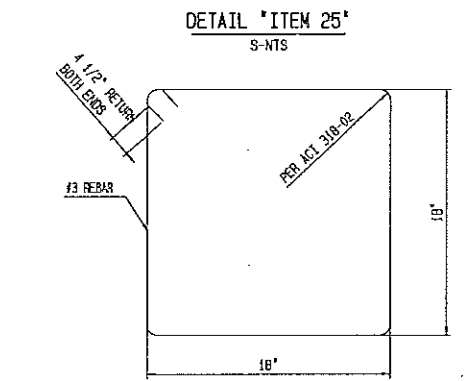
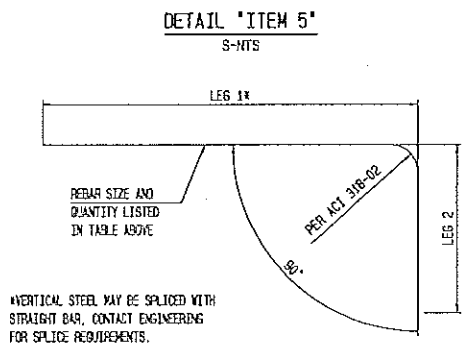
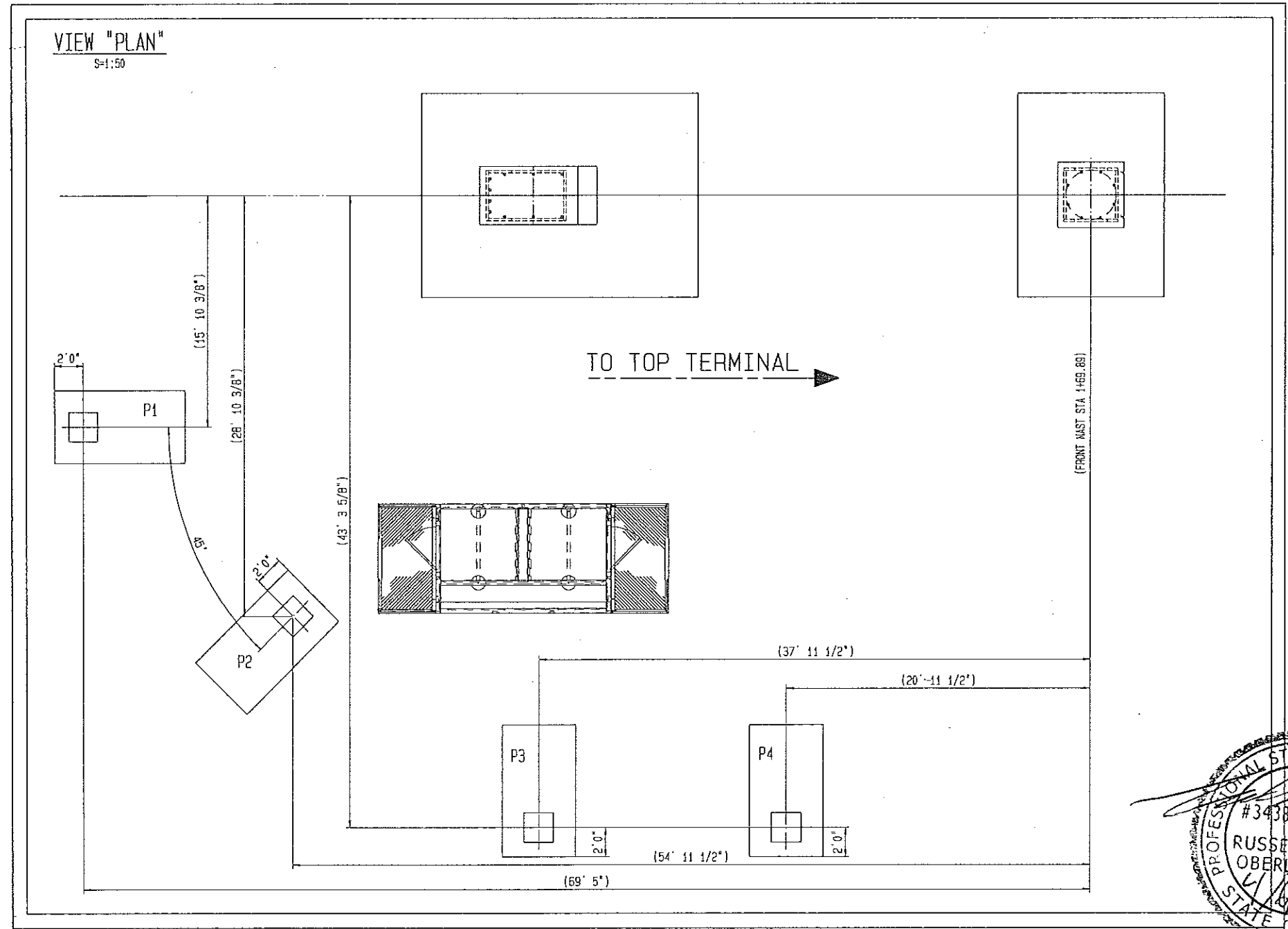

- NOTES:
- For general specifications see 90001186NAD005103.
 - Space Vertical Steel evenly in rebar hoops.
 - All Anchor Bolts have 7" Projection with 2" grout.
 - All rebar shall be ASTM A615 (60 KSI) or G400 metric.
 - All rebar dimensions shown are out to out.
 - All rebar shall be bent in accordance with ACI 318-14.
 - All rebar splices shall be in accordance with ACI 318-14.

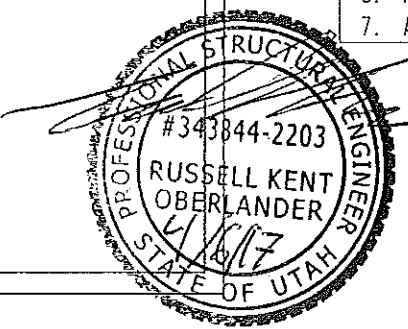

DATE	BY	DESCRIPTION	SCALE	DATE	BY
0			1/250	2017-04-07	

CONCRETE PARTS KIT 55053056

Doppelmayr
SINDBASTEN / WILLOCAT
ORDER SAA0002518

PARKING FOUNDATION SCHEDULE
UNIGS-W 6-CLD 5.6M

90007974NAD005102

7" A.B. Proj.
w/ 2" grout unless
noted otherwise on the
Footling Schedule Drawing

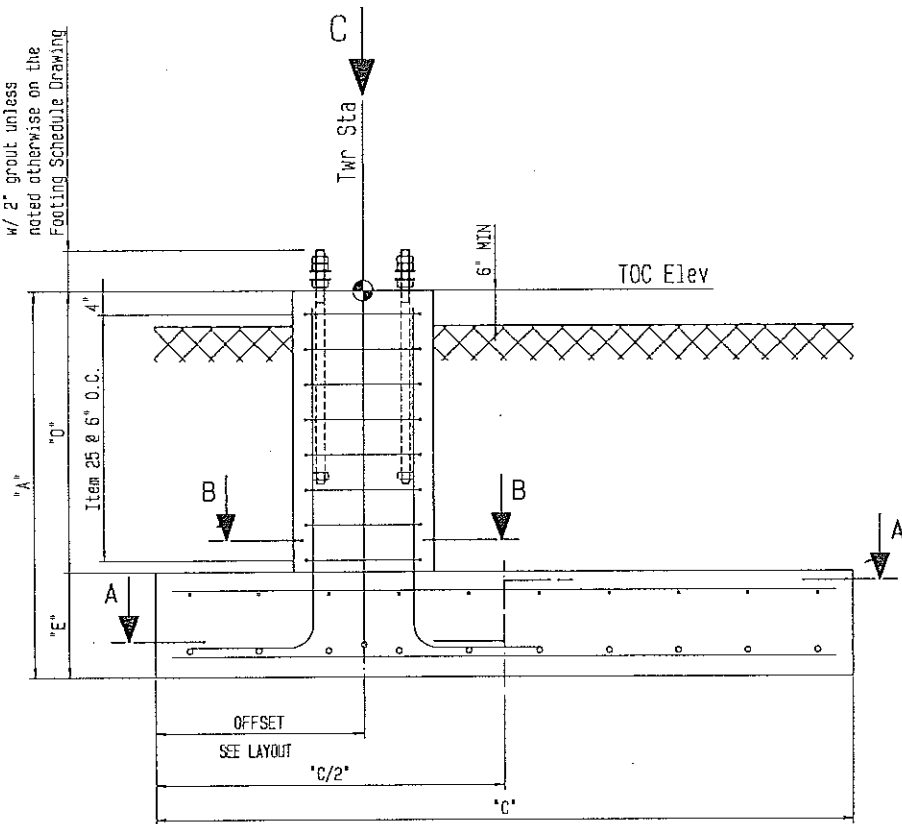

SECTION "A-A"
S=1:15

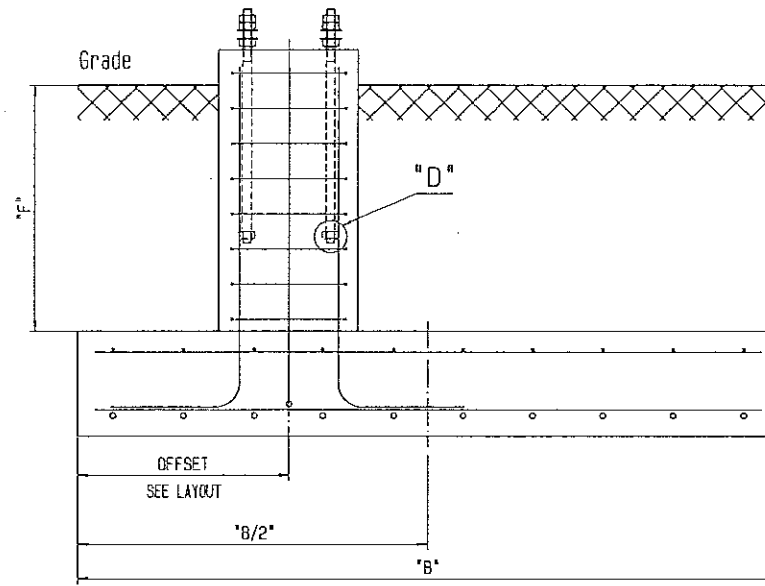
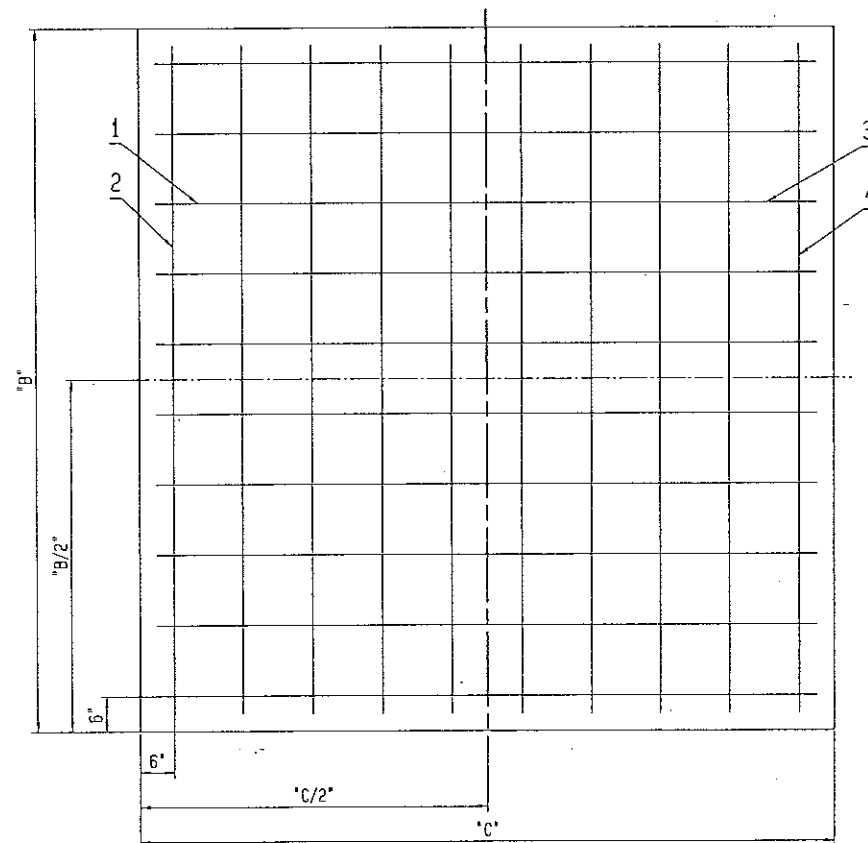

SECTION "B-B"
S=1:10

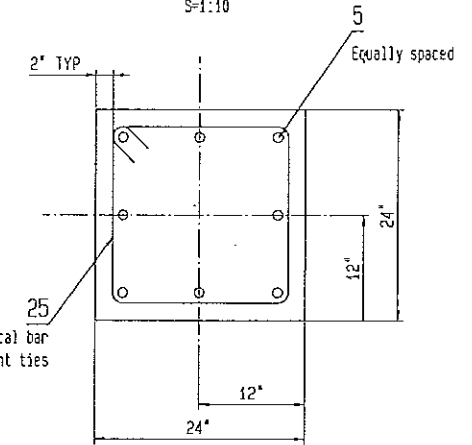

Hooks must engage vertical bar
Stagger hook location for adjacent ties

VIEW "C"
S=1:10

4 BOLT
ID#55027756

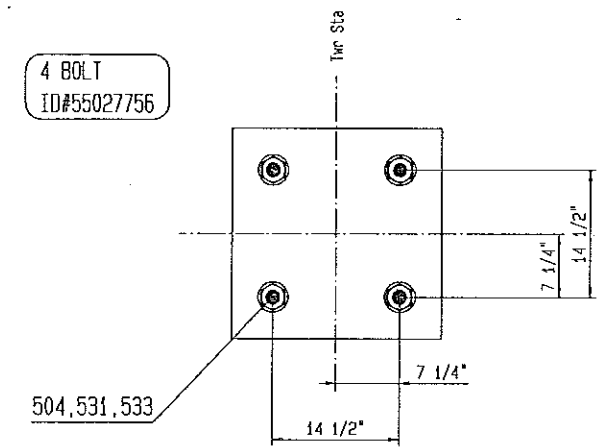

DETAIL "D"
S=1:2

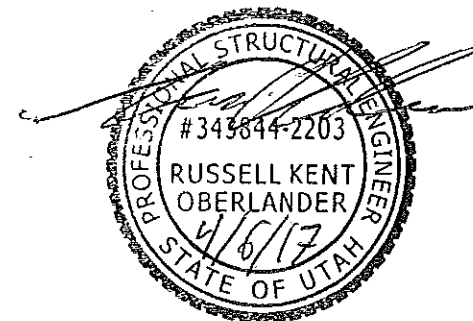
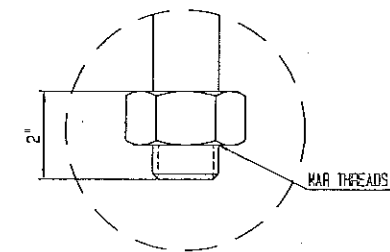

8	ADDED NOTES IN SECTION "B-B"	2015-07-09	FARHAN LIAQAT	24 SQ, 4X14.5	55027756
DATE	NAME	DATE	SCALE	DATE	NAME
0	0	0	1/15	2017-04-07	FARHAN LIAQAT
PROJECT	DESCRIPTION	SCALE	DATE	DATE	NAME
Doppelmayr CTEC	24 INCH SQUARE PEDESTAL	1/15	2017-04-07	2017-04-07	FARHAN LIAQAT
ORDER	QTY	UNIT	WEIGHT	DATE	NAME
PARK FTR - SPREAD FOOTING	1	KG	9000.4948	2017-04-07	FARHAN LIAQAT
4 BOLT, 14 1/2 INCH SQ BP					
24 INCH SQUARE PEDESTAL					
DRAWING NO.					90004948NAD005102 a

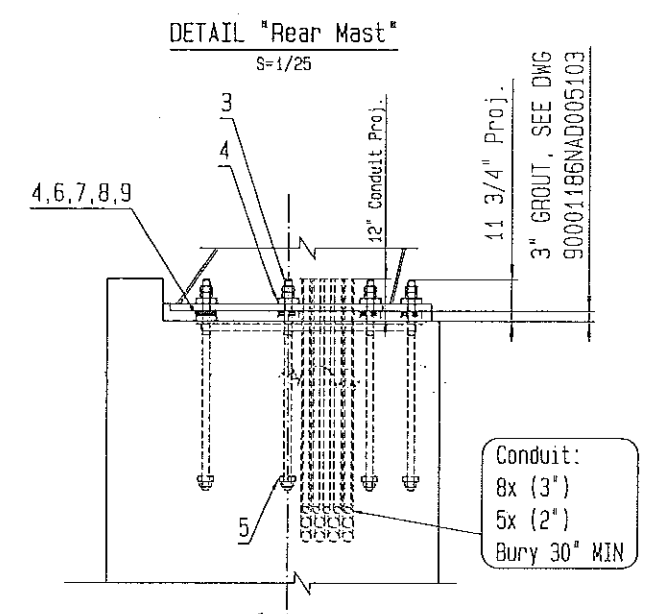
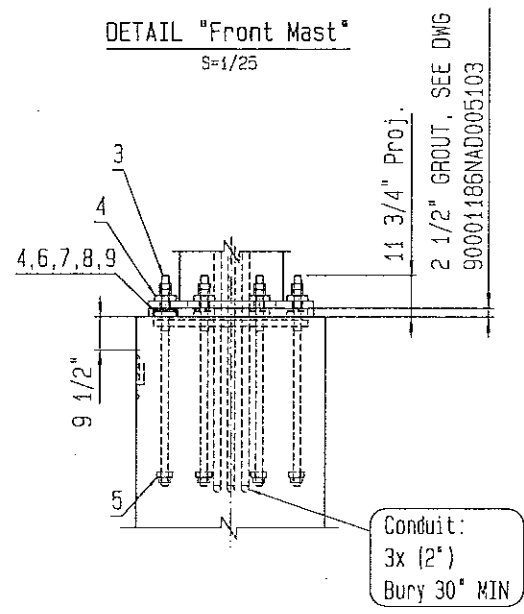
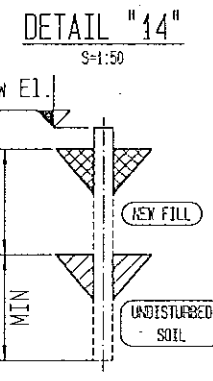
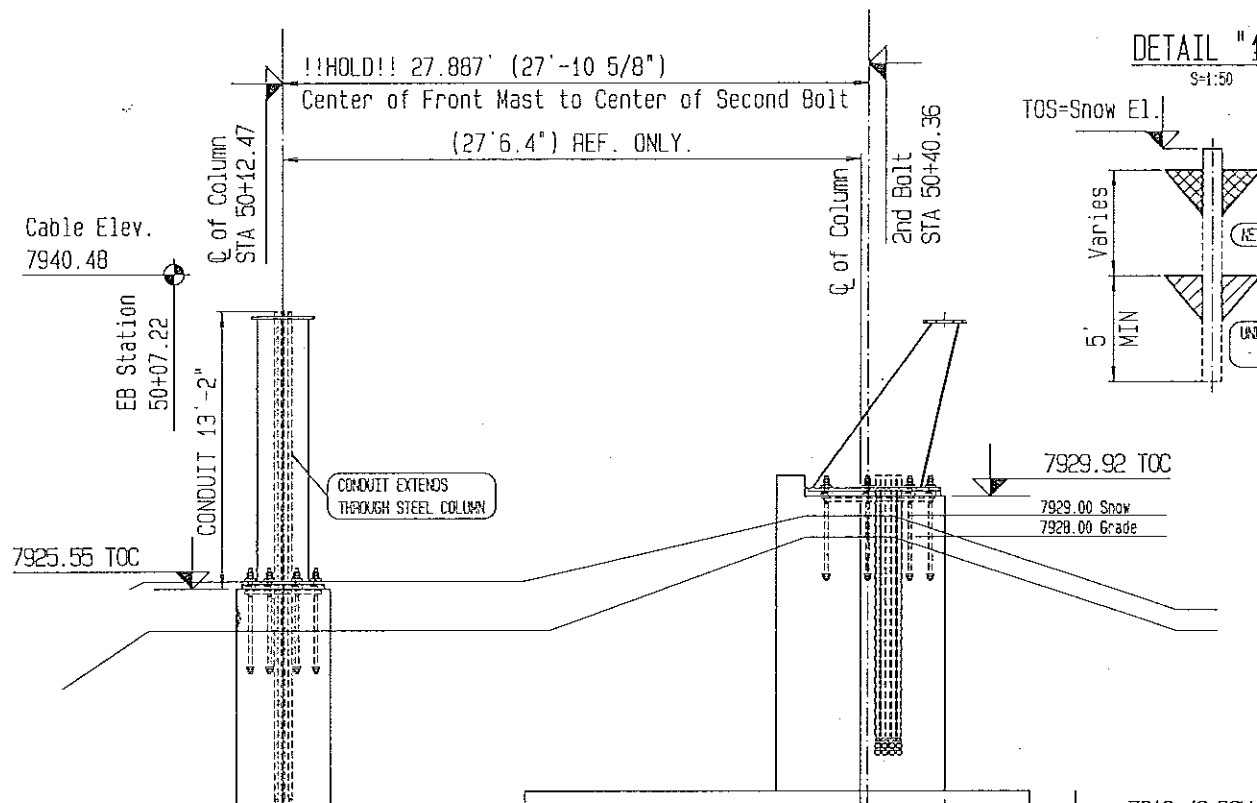

Rear Mast Foundation
for Concrete & Rebar see
ID 55051671

Front Mast Foundation
for Concrete & Rebar see
ID 55051670

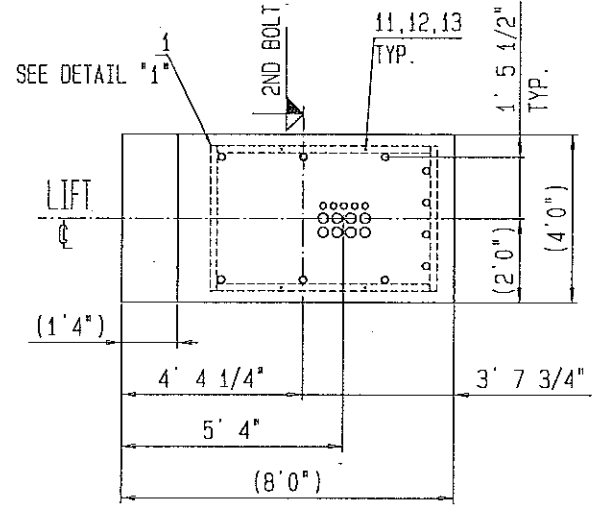
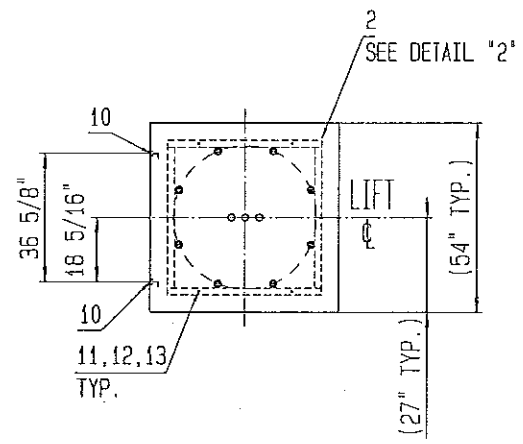

DETAIL "2"
S=1:12.5
FIELD VERIFY DIMS
PRIOR TO POUR

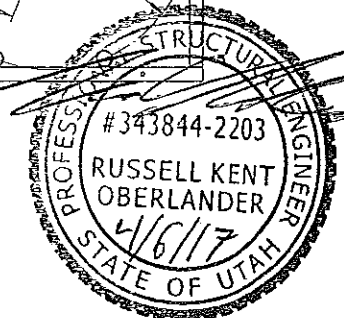
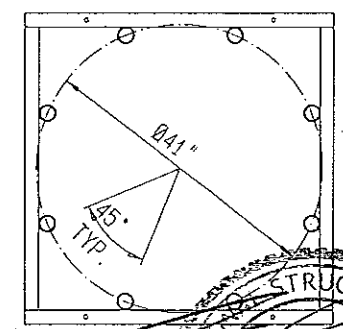
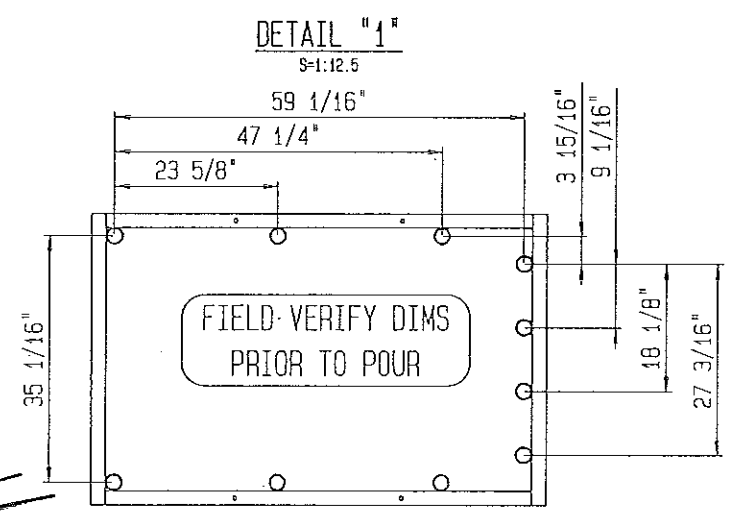

To Opposite Terminal

RIGHT HAND UP

SEE DETAIL "14"

NO.	REVISION	DATE	NAME	DESCRIPTION	SCALE	DATE	NAME
0					1/50	2017-02-02	Foran Liu
<p>CONCRETE PARTS KIT 55051669</p> <p>DRIVE STATION UNIGS-S 6-OLD</p> <p>90007822NAD005101</p>							

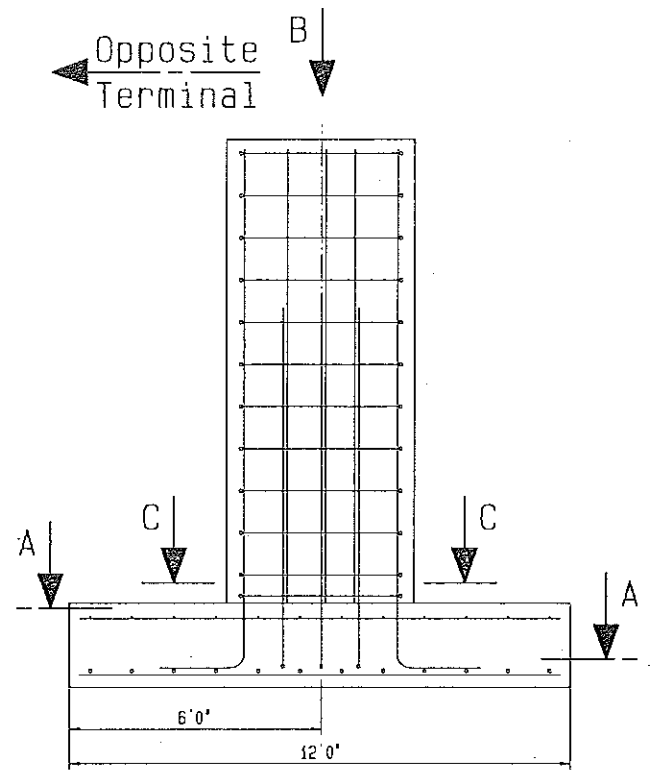

SECTION "A-A"
Ech. 1:25

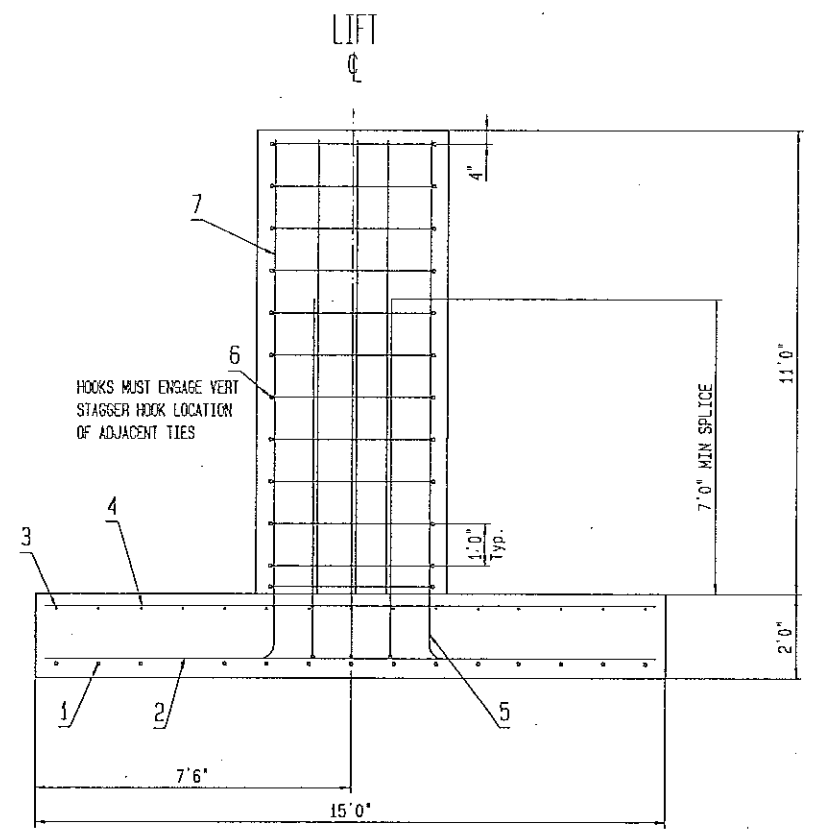
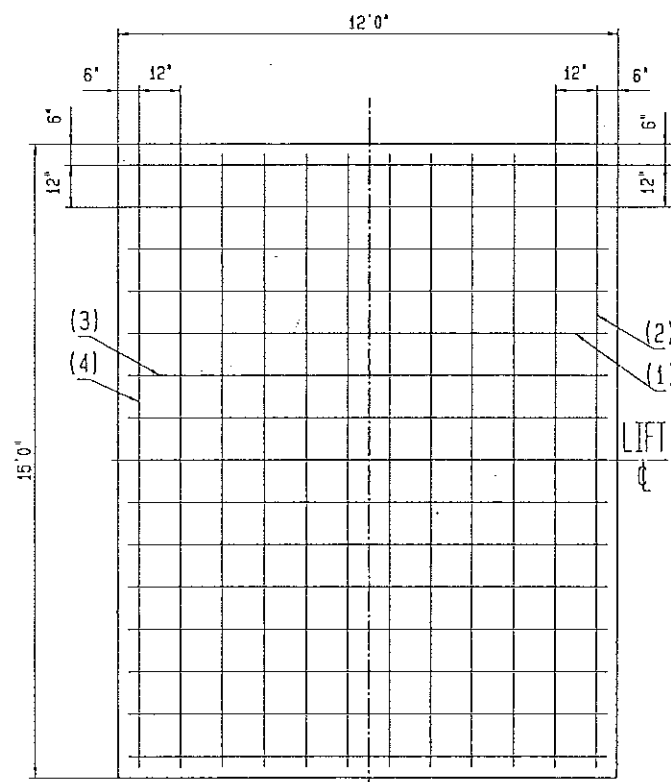

VIEW "B"
Ech. 1:25

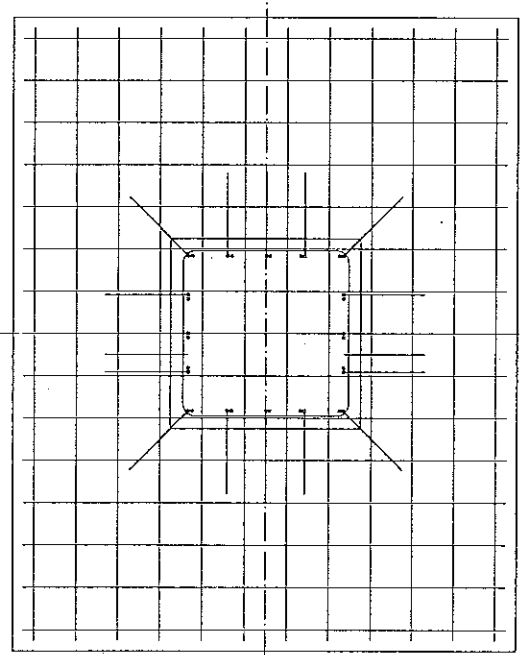

SECTION "C-C"
Ech. 1:25

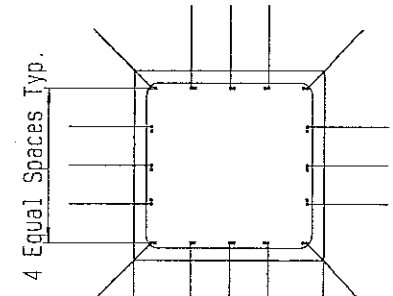

CONCRETE VOLUME :
PAD: 13.3 YDS³
COLUMN: 8.3 YDS³
TOTAL: 21.6 YDS³

- NOTES:
- All rebar shall be ASTM A615 (60 KSI) or G400 metric.
 - All rebar dimensions shown are out to out.
 - All rebar shall be bent in accordance with ACI 318-14.
 - All rebar splices shall be in accordance with ACI 318-14.
 - For grounding & concrete specs see dwg 90001186NAD005103.
 - Minimum concrete cover = 3".
 - Assumed soil pressure = 3200 psf.
 - Minimum backfill 9'0".

shape	item	quant	Ø	length
STRAIGHT	1	15	#8	11'6"
STRAIGHT	2	12	#8	14'6"
STRAIGHT	3	15	#4	11'6"
STRAIGHT	4	12	#4	14'6"
24" 9'0"	5	16	#9	11'0"
47" 47" 1/4"	6	12	#3	16'2"
STRAIGHT	7	16	#9	10'9"

FOR CONDUIT, ANCHOR BOLT, TEMPLATE, EMBEDS, AND OTHER DETAILS SEE FOUNDATION LAYOUT.

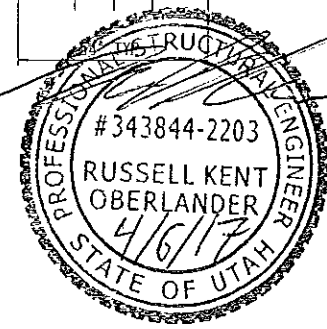

REVISED	DATE	NAME	DESCRIPTION	SCALE	DATE	NAME
0				1/25	2017-04-07	

Doppelmayr
 250 West 500 South
 Salt Lake City, UT 84119
 PHONE: 801-466-1111
 FAX: 801-466-1112
 WWW: WWW.DOPPELMAYR.COM

ORDER: SA00002518
 QUANTITY: X
 UNIT: kg
 DATE: 2017-04-07
 BY: 800555

PROJECT: SNOWBASIN / WILDCAT
 DRAWING NO.: 90007823NAD005101
 DRAWING TITLE: FRONT MAST FOUNDATION (TOP)
 DRIVE STATION: UNITS-S 6-CLD

DETAIL: 55051670
 SCALE: 1/25
 DATE: 2017-04-07
 NAME:

This drawing is the intellectual property of Doppelmayr USA, Inc. This drawing or information as our property and must not be copied nor utilized in whole or in part without permission and is subject to change without notice.

← Opposite Terminal

HOOKS MUST ENGAGE VERT STAGGER HOOK LOCATION OF ADJACENT TIES

FOR CONDUIT, ANCHOR BOLT, TEMPLATE, EMBEDS, AND OTHER DETAILS SEE FOUNDATION LAYOUT.

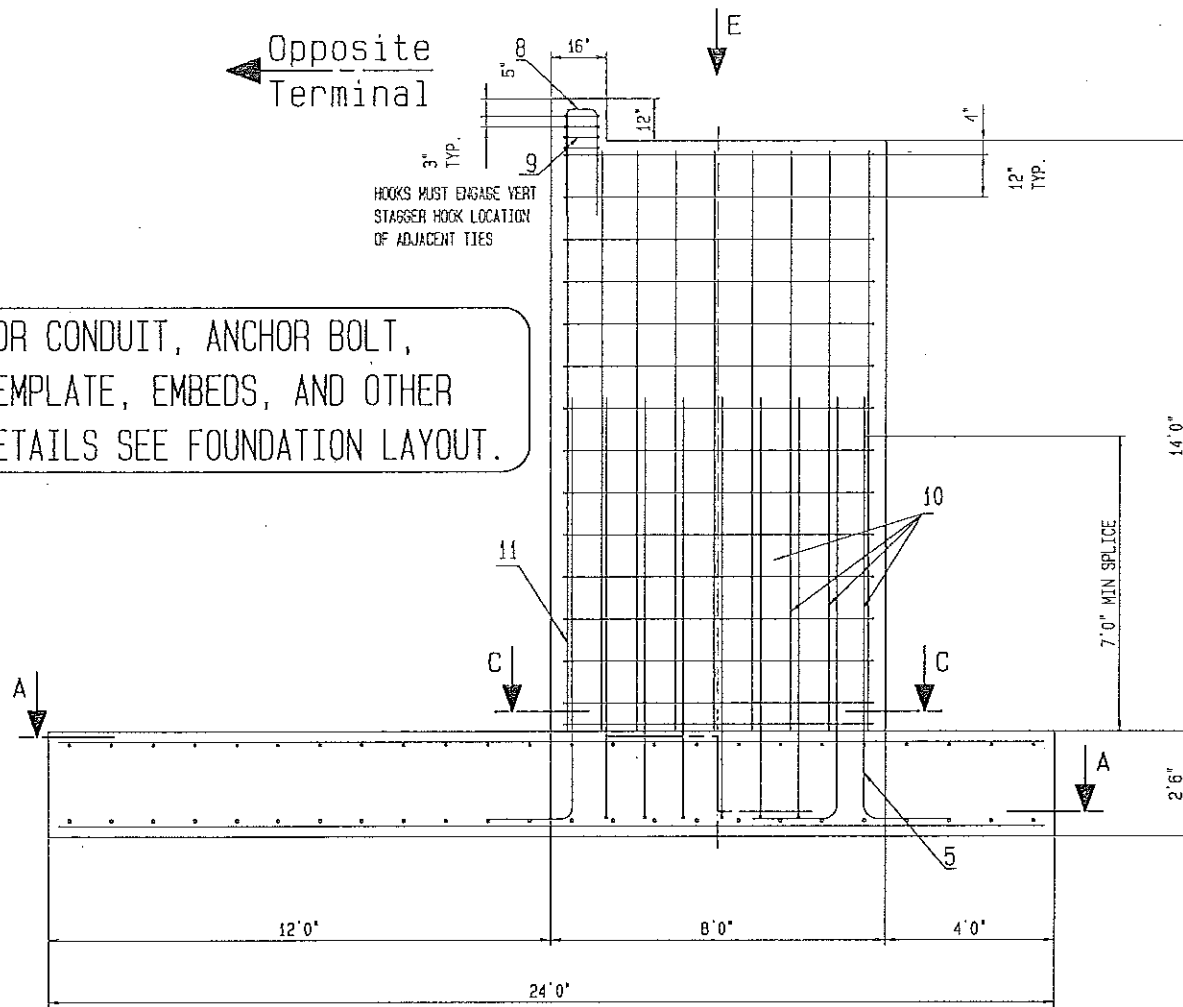

SECTION "A-A"
Ech. 1:25

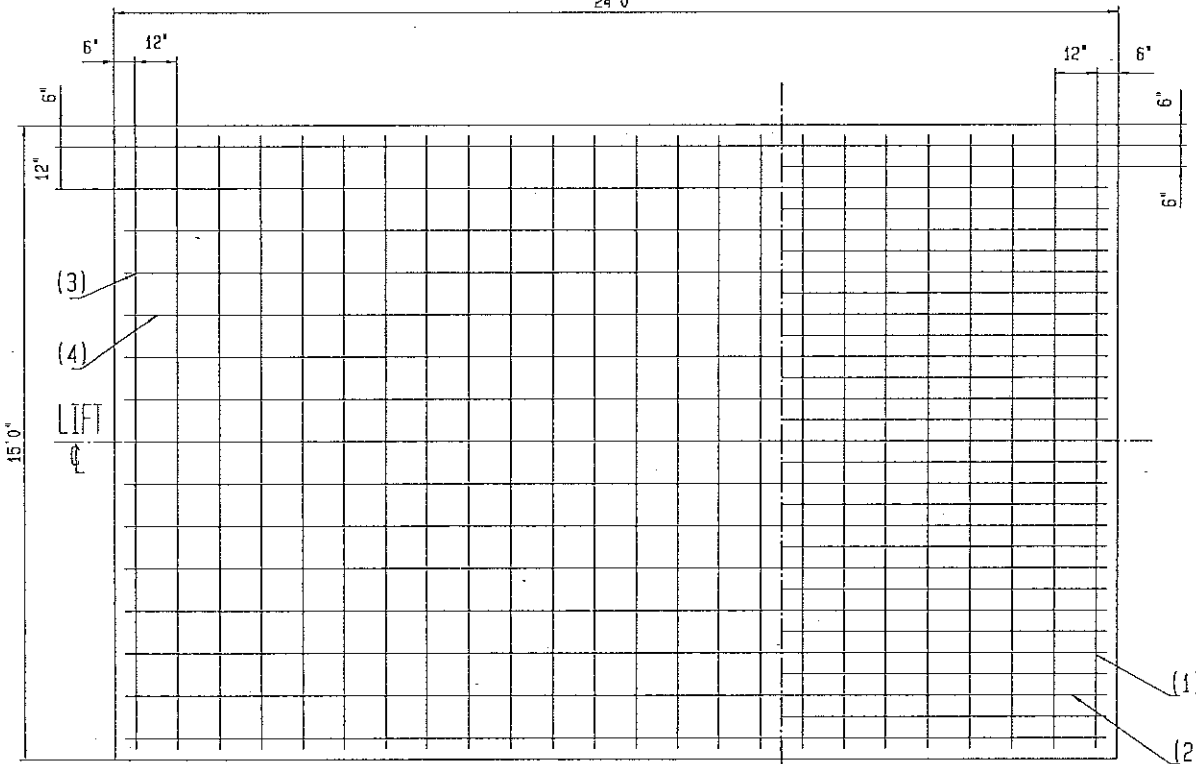

SECTION "C-C"
Ech. 1:25

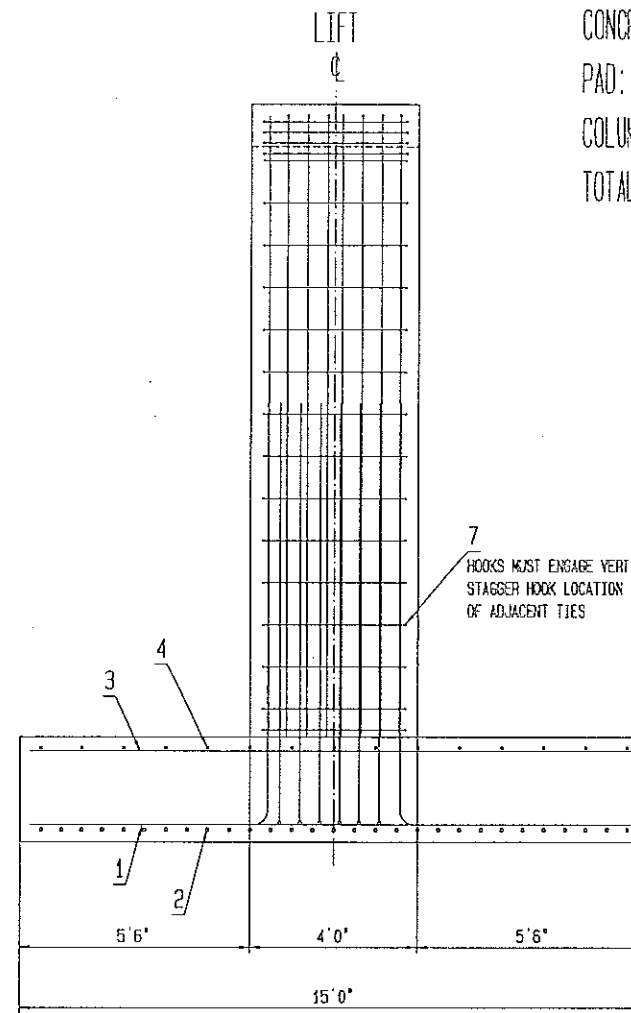

VIEW "E"
Ech. 1:25

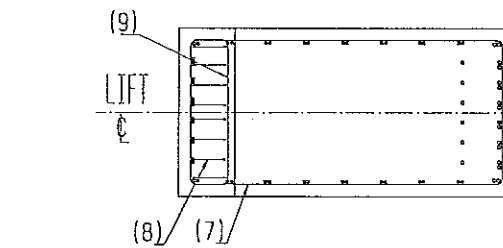

SECTION "C-C"
Ech. 1:25

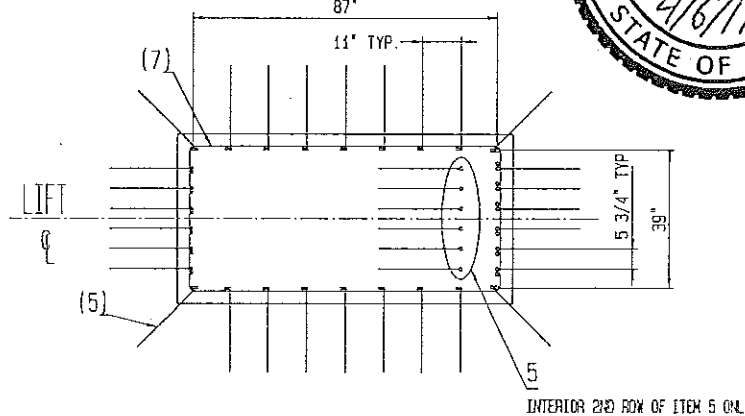

CONCRETE VOLUME :
PAD: 33.3 YDS'3
COLUMN: 16.8 YDS'3
TOTAL: 50.1 YDS'3

NOTES:

- All rebar shall be ASTM A615 (60 KSI) or G400 metric.
- All rebar dimensions shown are out to out.
- All rebar shall be bent in accordance with ACI 318-14.
- All rebar splices shall be in accordance with ACI 318-14.
- For grounding & concrete specs see dwg 90001186NAD005103.
- Minimum concrete cover = 3".
- Assumed soil pressure = 3100 psf.
- Minimum backfill 12'0".

shape	item	quant	Ø	length
STRAIGHT	1	24	#8	14'6"
STRAIGHT	2	29	#9	23'6"
STRAIGHT	3	24	#6	14'6"
STRAIGHT	4	15	#6	23'6"
24" 10'0"	5	36	#9	12'0"
6	-	-	-	-
41" 89" 1 1/2" 1 1/2"	7	15	#3	22'2"
9" 30"	8	8	#5	5'9"
0 1/2" 41 1/2" 1 1/2" 1 1/2"	9	4	#4	9'2"
STRAIGHT	10	22	#9	13'9"
STRAIGHT	11	8	#8	14'9"

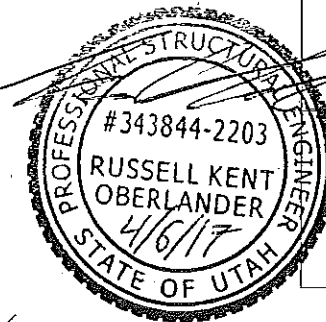

DATE	REVISION	BY	CHKD	DATE	REVISION	BY	CHKD
	0			2017-04-07			

Doppelmayr
 SCALE: 1/25
 PROJECT: SNOWBASIN / WILDCAT
 ORDER: SAAG002318
 DRAWING NO.: 90007824NAD005101

TWR #	FOOTING STATION	FOOTING ELEVATION	FOOTING DESCRIPTION	FOOTING ASSEMBLY	A	B	C	D	E	F	CONCRETE REQ'D	PAD STEEL				PEDESTAL STEEL			
												BOTTOM LAYER		TOP LAYER		VERTICAL STEEL		HOOPS (ITEM 6)	HOOPS (ITEM 7)
												PAR. TO C (ITEM 1)	PERP. TO C (ITEM 2)	PAR. TO C (ITEM 3)	PERP. TO C (ITEM 4)	(ITEM 5)	(ITEM 5)		
[FEET]	[FEET]	[FEET]	[PERIMETER]	[TOTAL HEIGHT]	[PAD WIDTH]	[PAD LENGTH]	[PAD HEIGHT]	[PAD DEPTH]	[NO. REBARS]	[CUBIC YARDS]	[Ø/TYPE/SPACING/LENGTH]	[Ø/TYPE/SPACING/LENGTH]	[Ø/TYPE/SPACING/LENGTH]	[Ø/TYPE/SPACING/LENGTH]	[Ø/TYPE/SPACING/LENGTH]	[Ø/TYPE/SPACING/LENGTH]			
1	1+99.00	6530.00	42" RND, 0", 8X30	90005283NAD0005102 55029780	5' - 6"	8' - 0"	9' - 0"	4' - 0"	1' - 6"	3' - 6"	5.4	8 #6 @ 12" 8' - 6" LONG	9 #6 @ 12" 7' - 6" LONG	8 #3 @ 12" 8' - 6" LONG	9 #3 @ 12" 7' - 6" LONG	8 - #8	5' - 3" X 2' - 0"	12	-
2	3+38.00	6558.80	42" RND, 6", 8X30	90005284NAD0005102 55029784	5' - 6"	9' - 0"	7' - 0"	4' - 0"	1' - 6"	3' - 6"	4.9	9 #6 @ 12" 6' - 6" LONG	7 #6 @ 12" 8' - 6" LONG	9 #3 @ 12" 6' - 6" LONG	7 #3 @ 12" 8' - 6" LONG	8 - #8	5' - 4" X 2' - 0"	13	-
3	5+54.00	6616.50	42" RND, 6", 8X30	90005284NAD0005102 55029784	5' - 6"	11' - 0"	8' - 0"	4' - 0"	1' - 6"	3' - 6"	6.3	11 #6 @ 12" 7' - 6" LONG	8 #7 @ 12" 10' - 6" LONG	11 #3 @ 12" 7' - 6" LONG	8 #3 @ 12" 10' - 6" LONG	8 - #8	5' - 4" X 2' - 0"	13	-
4	10+00.00	6690.80	42" RND, 6", 8X30	90005284NAD0005102 55029784	5' - 6"	11' - 0"	8' - 0"	4' - 0"	1' - 6"	3' - 6"	6.3	11 #6 @ 12" 7' - 6" LONG	8 #6 @ 12" 10' - 6" LONG	11 #3 @ 12" 7' - 6" LONG	8 #3 @ 12" 10' - 6" LONG	8 - #8	5' - 4" X 2' - 0"	13	-
5	12+78.00	6761.10	42" RND, 6", 8X30	90005284NAD0005102 55029784	5' - 6"	11' - 0"	8' - 0"	4' - 0"	1' - 6"	3' - 6"	6.3	11 #6 @ 12" 7' - 6" LONG	8 #6 @ 12" 10' - 6" LONG	11 #3 @ 12" 7' - 6" LONG	8 #3 @ 12" 10' - 6" LONG	8 - #8	5' - 4" X 2' - 0"	13	-
6	16+50.00	6874.80	48" RND, 12", 12X30	90005837NAD0005102 55037145	7' - 6"	12' - 0"	9' - 0"	6' - 0"	1' - 6"	3' - 6"	8.8	12 #6 @ 12" 8' - 6" LONG	9 #6 @ 12" 11' - 6" LONG	12 #3 @ 12" 8' - 6" LONG	9 #3 @ 12" 11' - 6" LONG	12 - #8	7' - 7" X 2' - 0"	-	20
7	19+90.00	7038.50	42" RND, 12", 12X30	90005283NAD0005102 55029789	7' - 6"	11' - 0"	8' - 0"	6' - 0"	1' - 6"	3' - 6"	7	11 #6 @ 12" 7' - 6" LONG	8 #7 @ 12" 10' - 6" LONG	11 #3 @ 12" 7' - 6" LONG	8 #3 @ 12" 10' - 6" LONG	12 - #8	7' - 6" X 2' - 0"	20	-
8	23+44.00	7169.50	42" RND, 12", 12X30	90005283NAD0005102 55029789	7' - 6"	11' - 0"	8' - 0"	6' - 0"	1' - 6"	3' - 6"	7	11 #6 @ 12" 7' - 6" LONG	8 #7 @ 12" 10' - 6" LONG	11 #3 @ 12" 7' - 6" LONG	8 #3 @ 12" 10' - 6" LONG	12 - #8	7' - 6" X 2' - 0"	20	-
9	25+45.00	7246.90	42" RND, 12", 8X30	90005283NAD0005102 55029788	7' - 6"	11' - 0"	8' - 0"	6' - 0"	1' - 6"	3' - 6"	7	11 #6 @ 12" 7' - 6" LONG	8 #7 @ 12" 10' - 6" LONG	11 #3 @ 12" 7' - 6" LONG	8 #3 @ 12" 10' - 6" LONG	8 - #8	7' - 6" X 2' - 0"	20	-
10	29+55.00	7354.60	48" RND, 12", 12X30	90005837NAD0005102 55037145	9' - 6"	12' - 0"	10' - 0"	8' - 0"	1' - 6"	3' - 6"	10.4	12 #6 @ 12" 9' - 6" LONG	10 #7 @ 12" 11' - 6" LONG	12 #3 @ 12" 9' - 6" LONG	10 #3 @ 12" 11' - 6" LONG	12 - #8	9' - 7" X 2' - 0"	-	25
11	32+91.00	7511.00	42" RND, 12", 8X30	90005283NAD0005102 55029788	9' - 6"	9' - 0"	8' - 0"	8' - 0"	1' - 6"	3' - 6"	6.8	9 #6 @ 12" 7' - 6" LONG	8 #6 @ 12" 8' - 6" LONG	9 #3 @ 12" 7' - 6" LONG	8 #3 @ 12" 8' - 6" LONG	8 - #8	9' - 6" X 2' - 0"	26	-
12	35+81.00	7609.20	42" RND, 12", 8X30	90005283NAD0005102 55029788	9' - 6"	11' - 0"	8' - 0"	8' - 0"	1' - 6"	3' - 6"	7.7	11 #6 @ 12" 7' - 6" LONG	8 #7 @ 12" 10' - 6" LONG	11 #3 @ 12" 7' - 6" LONG	8 #3 @ 12" 10' - 6" LONG	8 - #8	9' - 6" X 2' - 0"	26	-
13	37+85.00	7665.70	42" RND, 6", 12X30	90005284NAD0005102 55029785	9' - 6"	13' - 0"	8' - 0"	8' - 0"	1' - 6"	3' - 6"	8.6	13 #6 @ 12" 7' - 6" LONG	8 #9 @ 12" 12' - 6" LONG	13 #3 @ 12" 7' - 6" LONG	8 #3 @ 12" 12' - 6" LONG	12 - #8	9' - 4" X 2' - 0"	25	-
14	43+45.00	7817.20	42" RND, 6", 12X30	90005284NAD0005102 55029785	9' - 6"	12' - 0"	8' - 0"	8' - 0"	1' - 6"	3' - 6"	8.2	12 #6 @ 12" 7' - 6" LONG	8 #8 @ 12" 11' - 6" LONG	12 #3 @ 12" 7' - 6" LONG	8 #3 @ 12" 11' - 6" LONG	12 - #8	9' - 4" X 2' - 0"	25	-
15	45+75.00	7876.80	42" RND, 0", 8X30	90005283NAD0005102 55029789	5' - 6"	8' - 0"	10' - 0"	4' - 0"	1' - 6"	3' - 6"	5.9	8 #6 @ 12" 9' - 6" LONG	10 #6 @ 12" 7' - 6" LONG	8 #3 @ 12" 9' - 6" LONG	10 #3 @ 12" 7' - 6" LONG	8 - #8	5' - 3" X 2' - 0"	12	-
16	47+00.00	7895.60	42" RND, 0", 8X30	90005283NAD0005102 55029789	5' - 6"	8' - 0"	8' - 0"	4' - 0"	1' - 6"	3' - 6"	5	8 #6 @ 12" 7' - 6" LONG	8 #6 @ 12" 7' - 6" LONG	8 #3 @ 12" 7' - 6" LONG	8 #3 @ 12" 7' - 6" LONG	8 - #8	5' - 3" X 2' - 0"	12	-
17	49+66.00	7903.70	42" RND, 0", 8X30	90005283NAD0005102 55029789	5' - 6"	8' - 0"	8' - 0"	4' - 0"	1' - 6"	3' - 6"	5	8 #6 @ 12" 7' - 6" LONG	8 #6 @ 12" 7' - 6" LONG	8 #3 @ 12" 7' - 6" LONG	8 #3 @ 12" 7' - 6" LONG	8 - #8	5' - 3" X 2' - 0"	12	-
TOTAL											116.6					262	46		

DETAIL "ITEM 5"
S-1:10

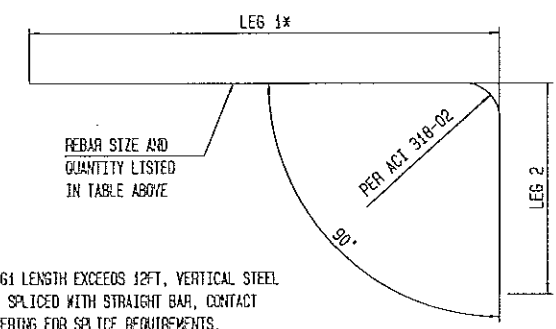

DETAIL "ITEM 6"
S-1:10

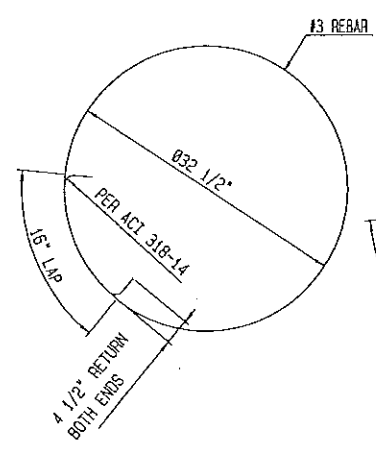

DETAIL "ITEM 7"
S-1:10

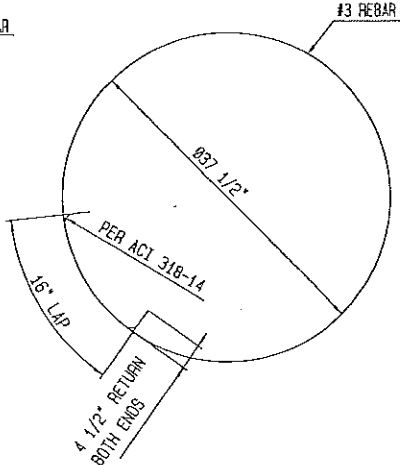

- NOTES:
- For general specifications see 90001186NAD0005103.
 - Space Vertical Steel evenly in rebar hoops.
 - All Anchor Bolts have 7" Projection with 2" grout EXCEPT towers 1 and 17 which have 9" Projection with 3" grout.
 - All rebar shall be ASTM A615 (60 KSI) or G400 metric.
 - All rebar dimensions shown are out to out.
 - All rebar shall be bent in accordance with ACI 318-14.
 - All rebar splices shall be in accordance with ACI 318-14.

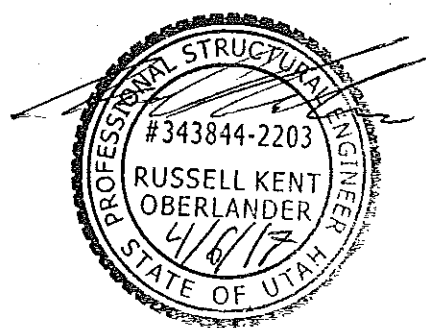

CONCRETE PARTS KIT		55051672	
SCALE	DATE	SCALE	DATE
1/250	2017-04-07	1/250	2017-04-07
PROJECT: SNOWBASIN / WILCOAT		DRAWING NO.: 90007825NAD0005102	
ORDER: SA0002518		ISSUE NO.: 1	
TOWER FOUNDATION SCHEDULE			
6-CLD 5.6M LINE GA.			

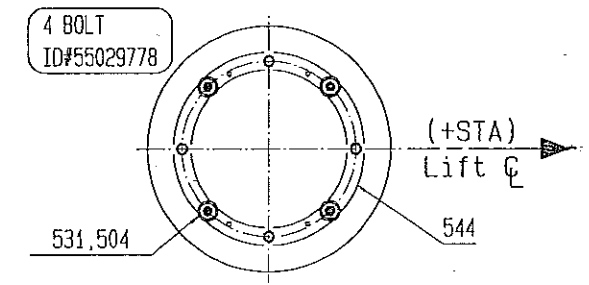
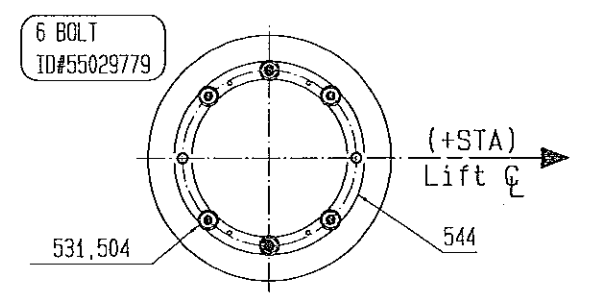
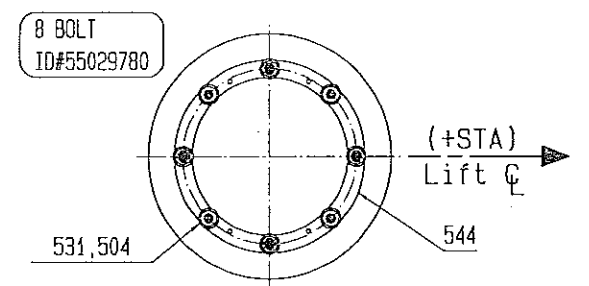
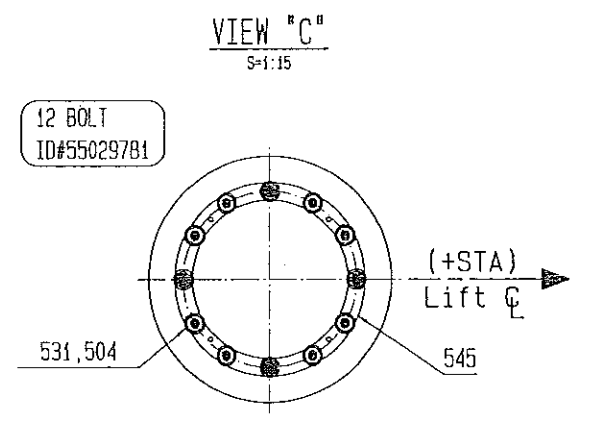
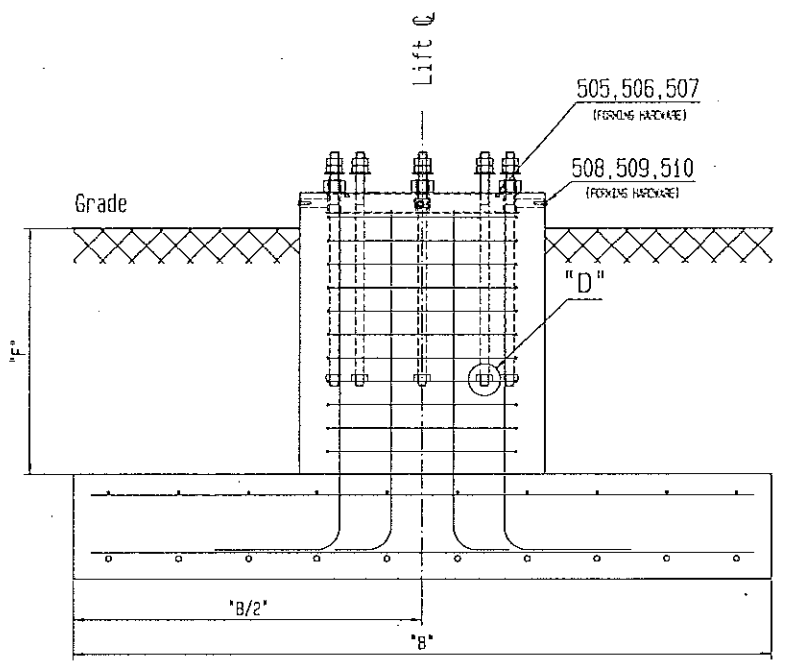
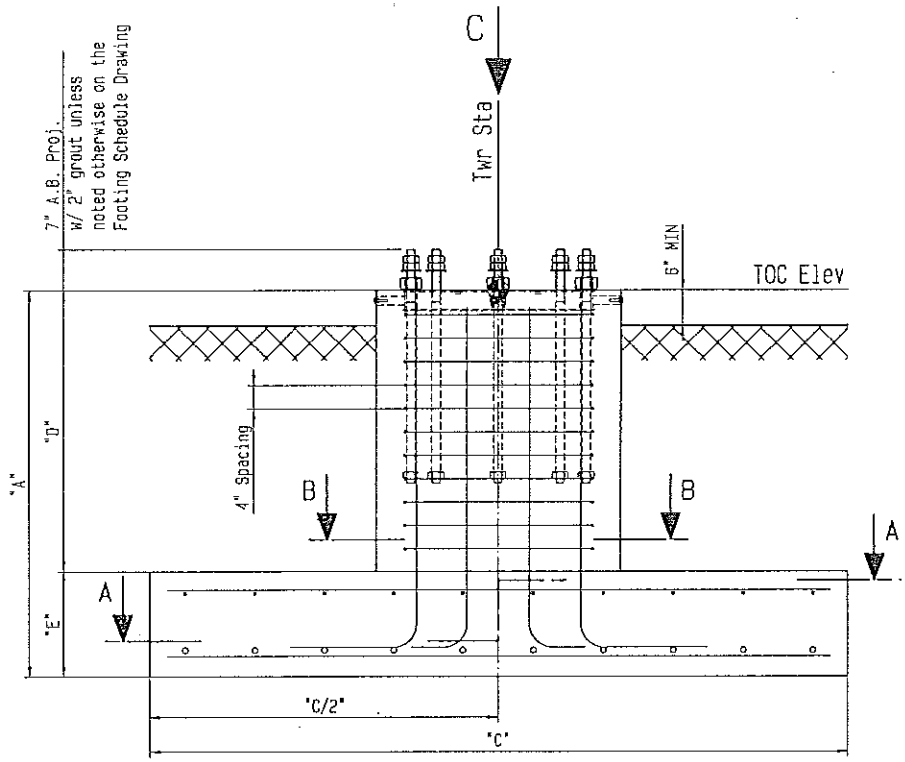

SECTION "A-A"
S=1:15

SECTION "B-B"
S=1:15

DETAIL "D"
S=1:2

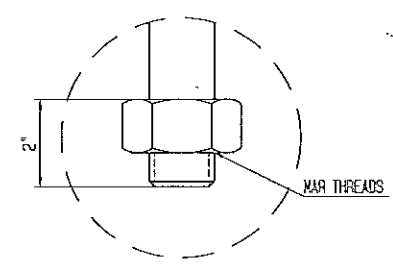
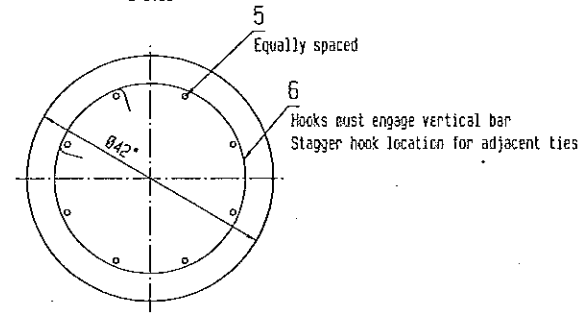
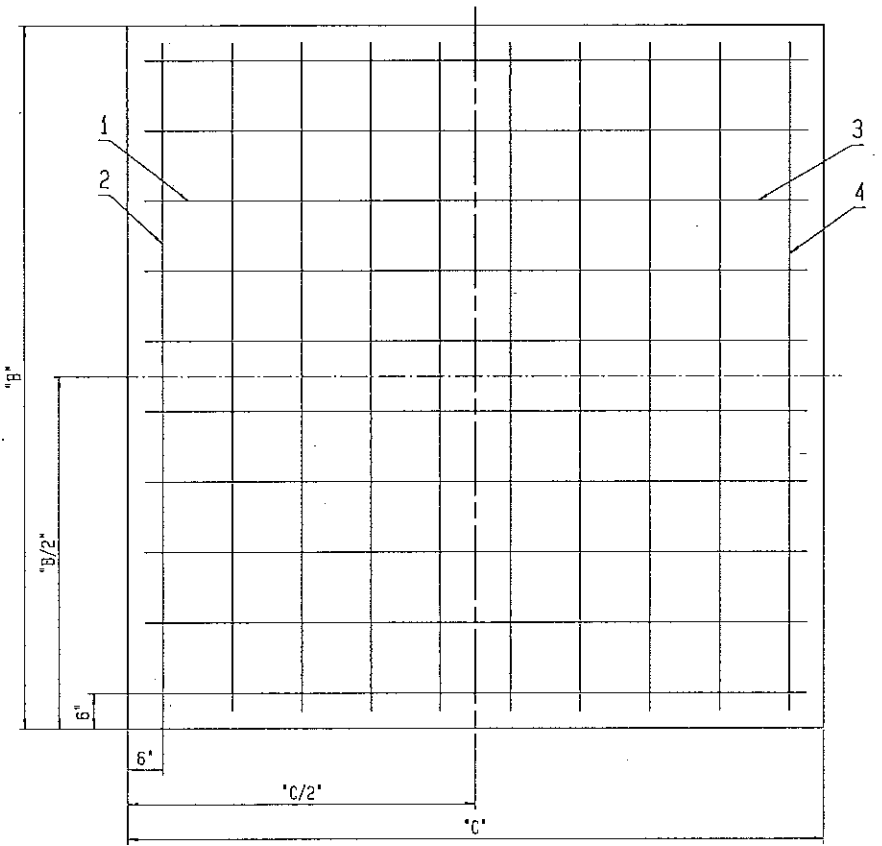

(+STA)
Lift C

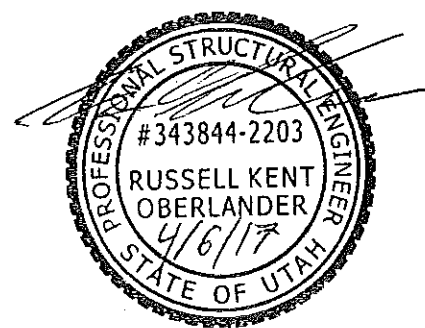

42ND, 006, 12X30	55029781
42ND, 006, 6X30	55029780
42ND, 006, 6X30	55029779
42ND, 006, 4X30	55029778

REVISED SECTION "B-B" TO CLARIFY CIRCULAR TIE PLACEMENT	DATE: 2016-07-01	BY: FAY/ML	SCALE: 1/15
DESIGNED BY: D. Doppelmayr	DATE: 2017-04-07	BY: FAY/ML	SCALE: 1/15
PROJECT: TWR FTR - SPREAD FOOTING		DATE: 2017-04-07	
DESCRIPTION: 4-12 BOLT, 30 INCH BC, 0 DEG 42 INCH ROUND PEDESTAL		DRAWING NO.: 90005283NAD005102 a	

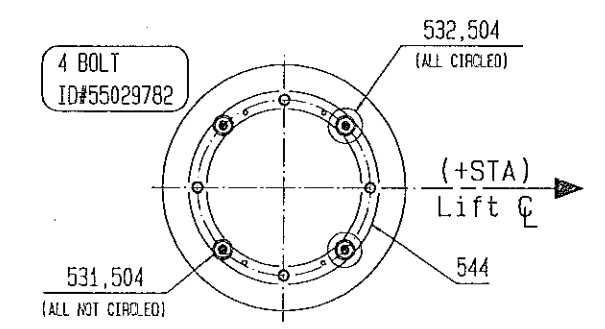
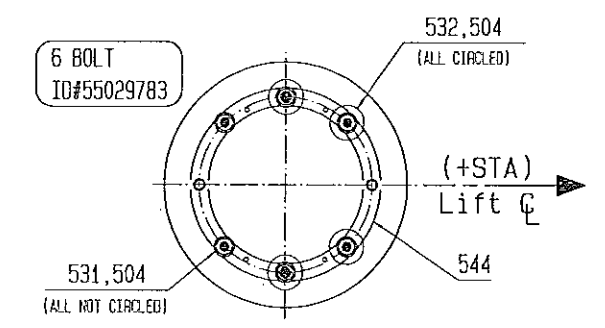
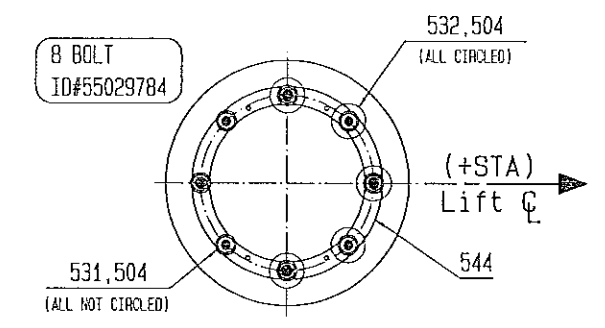
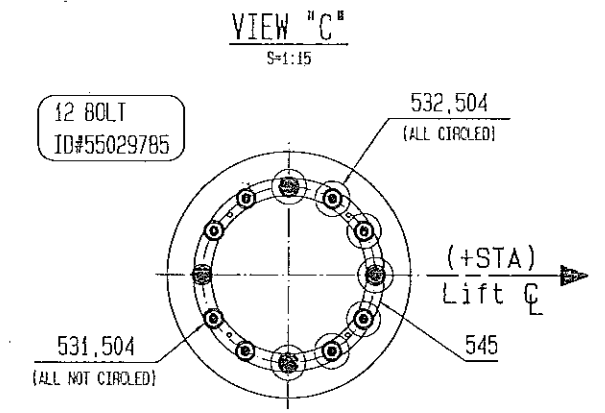
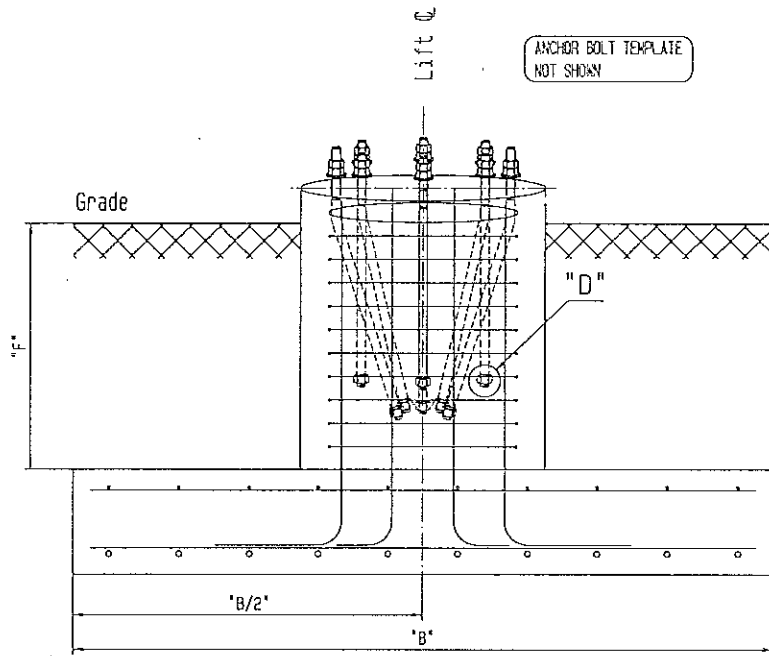
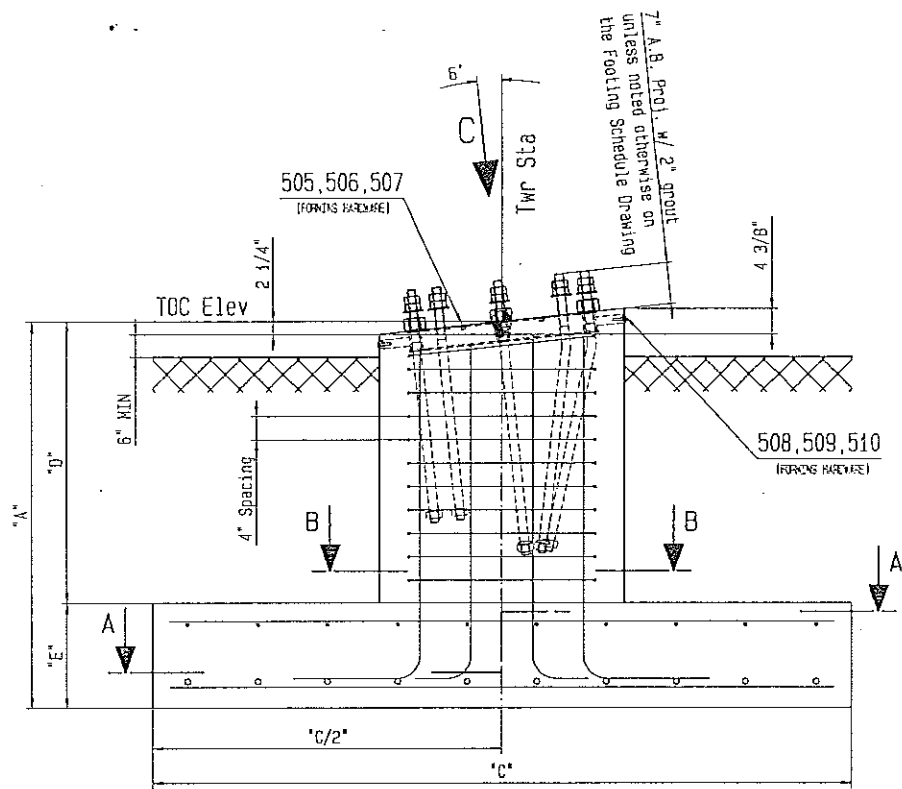

SECTION "A-A"
S=1:15

SECTION "B-B"
S=1:15

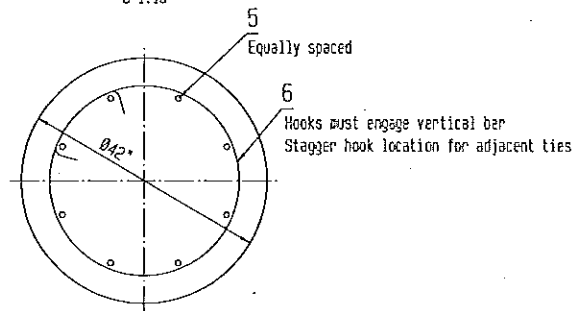

DETAIL "D"
S=1:2

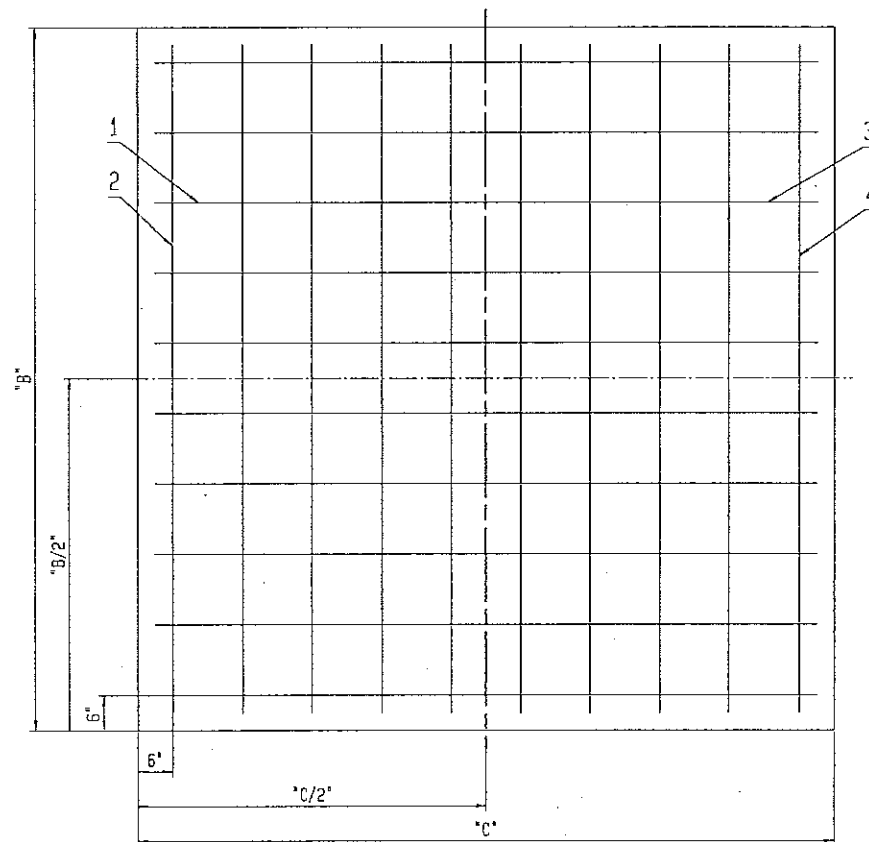
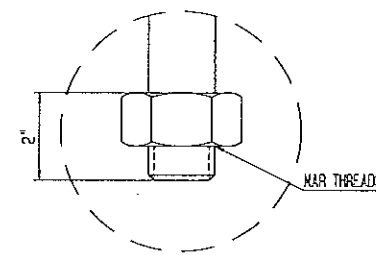

(+STA)
Lift C

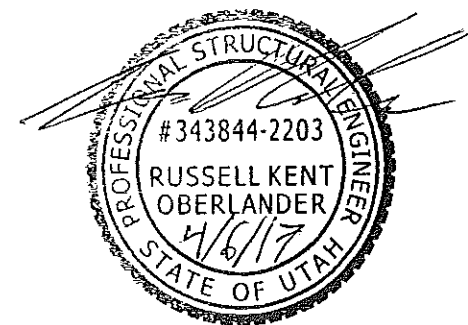

42ND, 60ES, 12X50	55029785
42ND, 60ES, 8X30	55029784
42ND, 60ES, 6X30	55029783
42ND, 60ES, 3X50	55029782

2	UPDATED SECTION "B-B" TO CLARIFY CIRCULAR TIE PLACEMENT	2016-07-01	Revision Log
1	ISSUED FOR PERMIT	2016-07-01	Revision Log

SCALE	DATE	NAME
1/15	2017-04-07	Revision Log
UNIT	DATE	NAME
kg	2017-04-07	Revision Log

PROJECT	ORDER	SCALE	DATE
TWR FTR - SPREAD FOOTING	0	1/15	2017-04-07
4-12 BOLT, 30 INCH BC, 6 DEGREE			
42 INCH ROUND PEDESTAL			

CREATING NO.	DATE
90005284NAD005102	2017-04-07

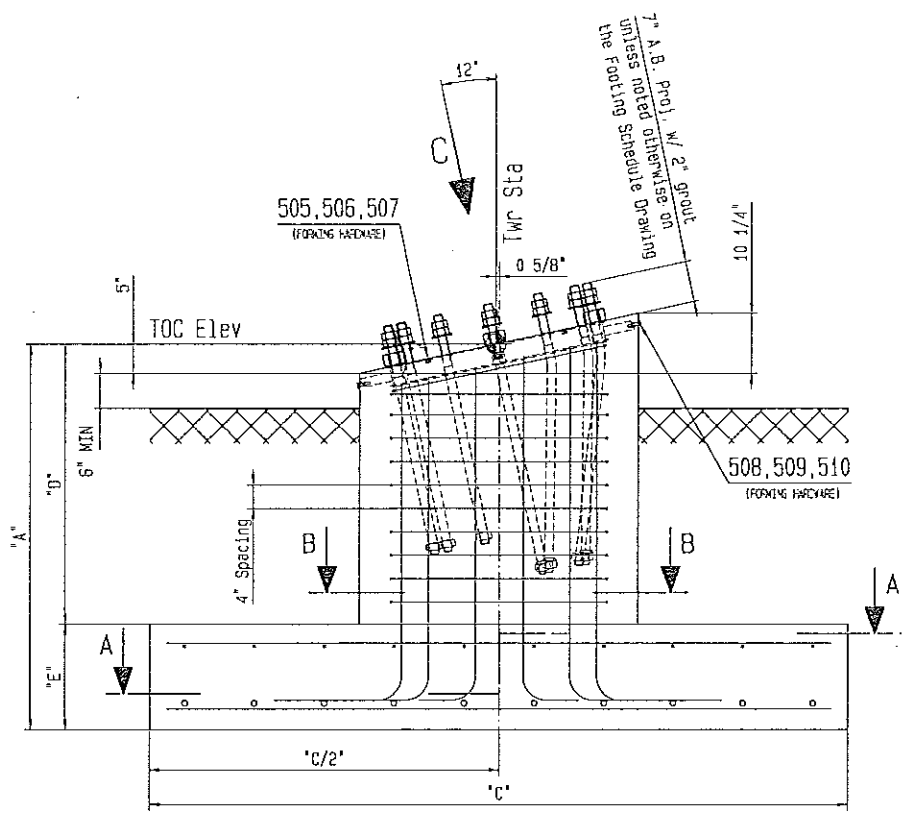

SECTION "A-A"
S=1:15

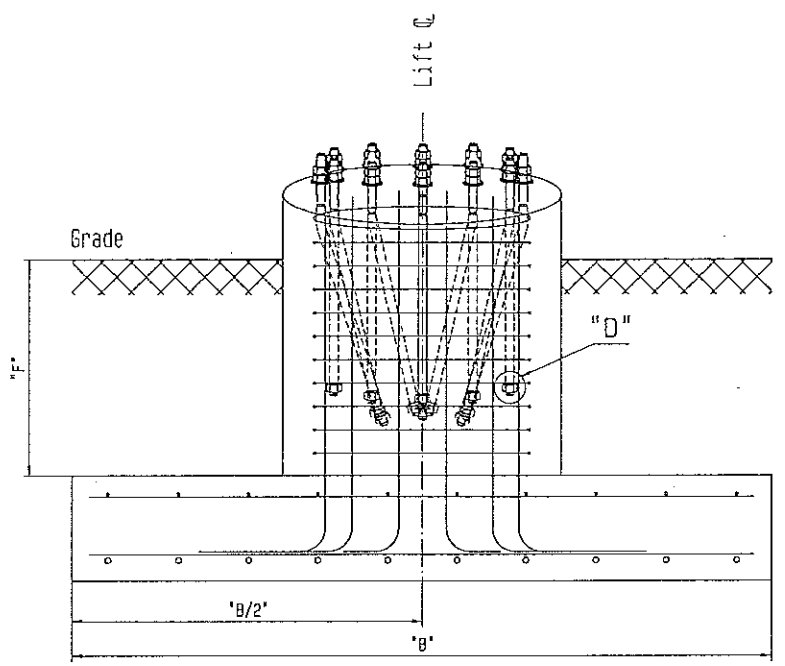
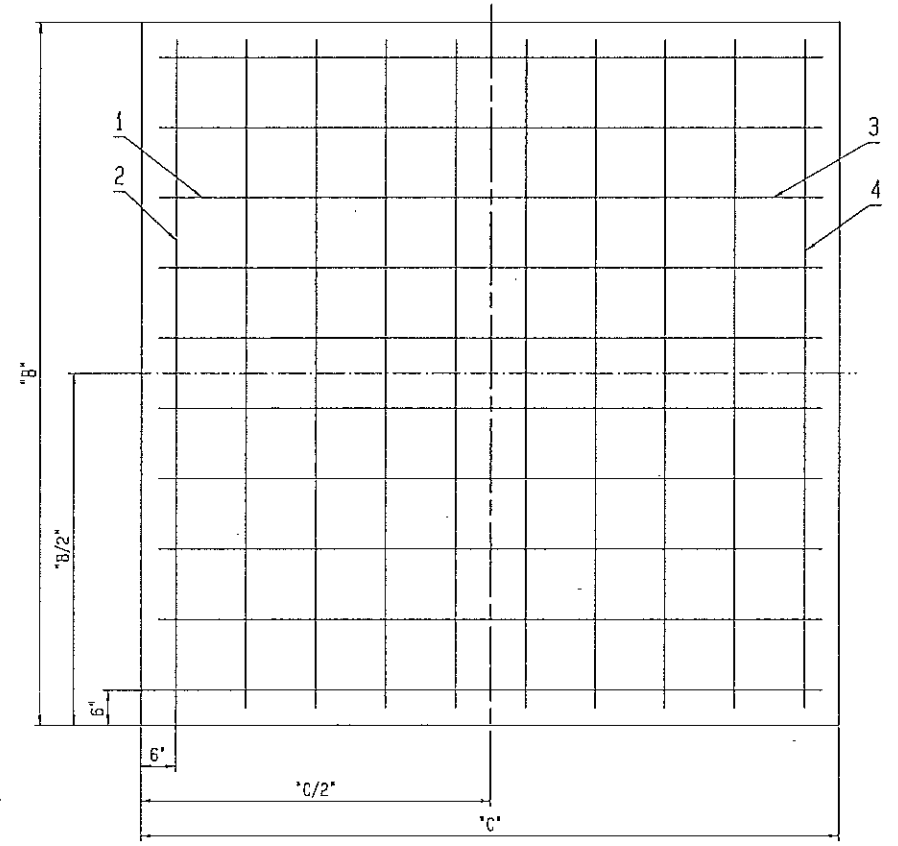

SECTION "B-B"
S=1:15

DETAIL "D"
S=1:2

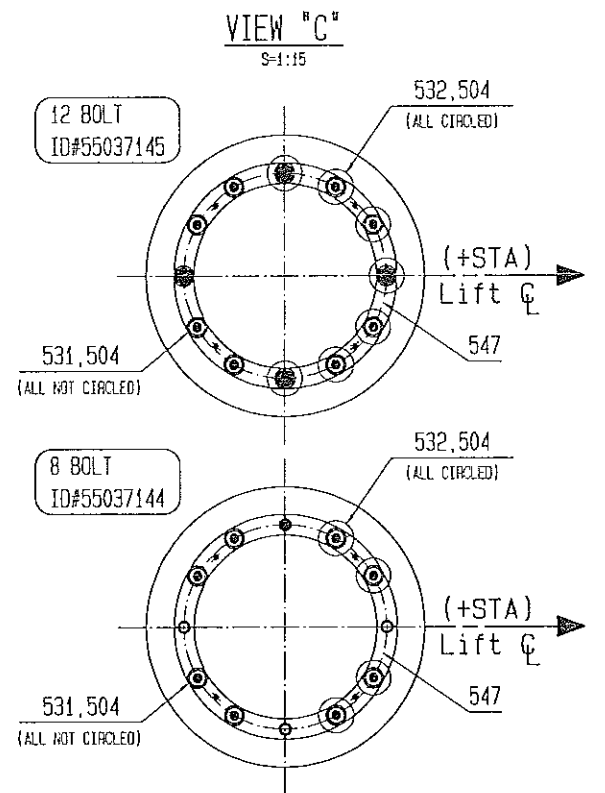
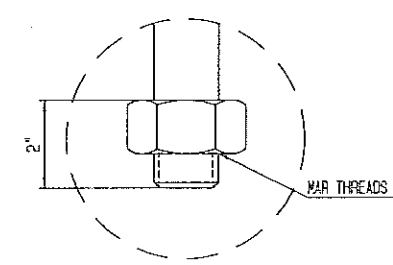
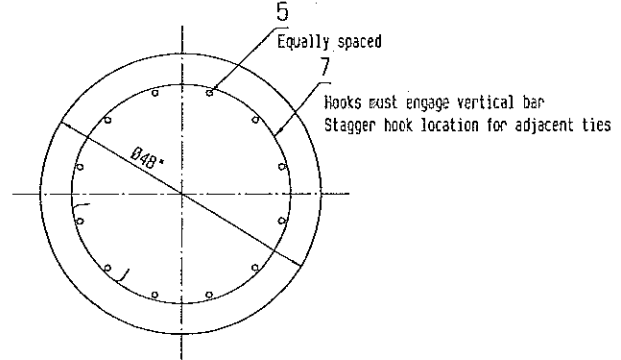

(+STA)
Lift C

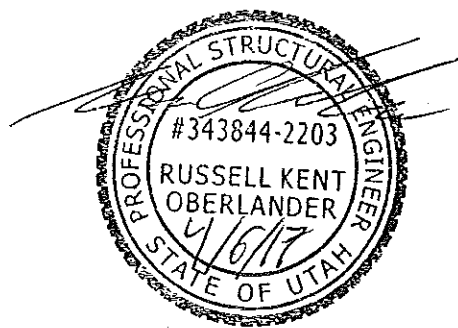

REV#	DATE	BY	CHKD	DESCRIPTION	SCALE	DATE	BY
0					1/15	2017-04-07	
Doppelmayr Doppelmayr Co., Inc. 200 West 500 South Salt Lake City, UT 84119				ORDER NO. X TWR FTR - SPREAD FOOTING 8-12 BOLT, 35 INCH BC, 12 DEGREE 48 INCH ROUND PEDESTAL	ORDER NO. 90005837NAD0005102	48NO, 12DEG, 12X35 55037145 48NO, 12DEG, 8X35 55037144	

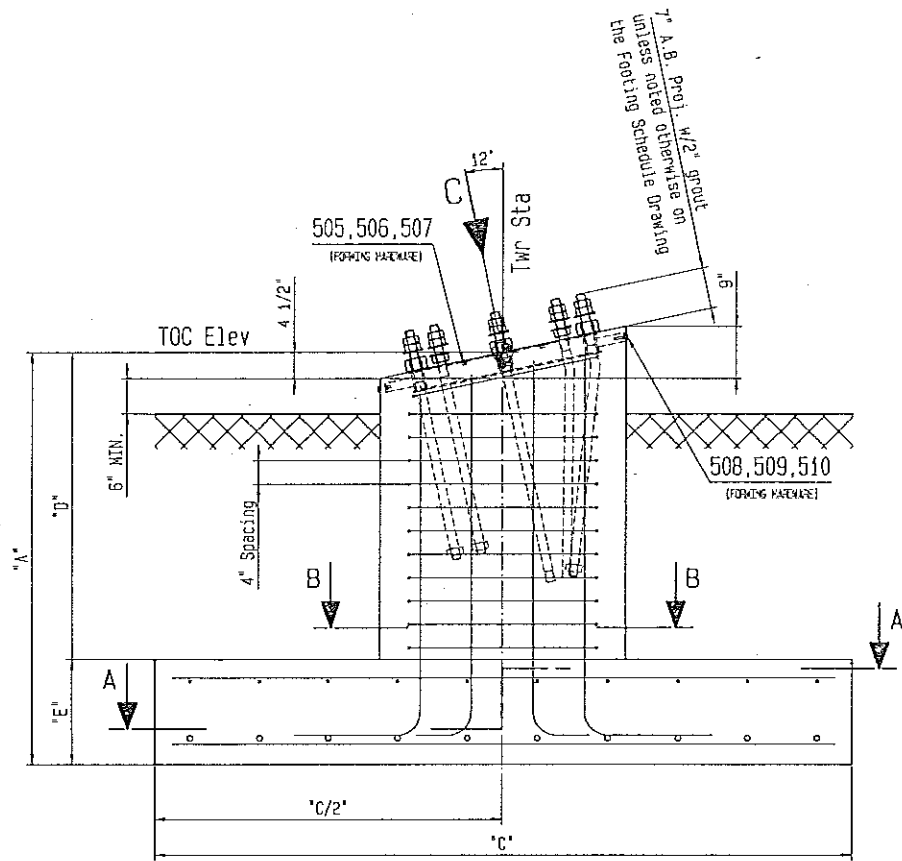

SECTION "A-A"
S-1:15

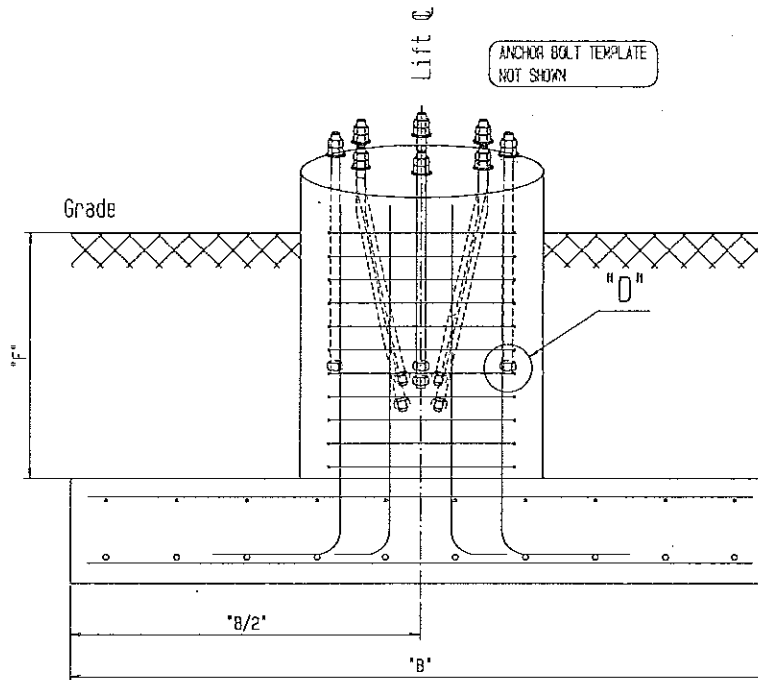

SECTION "B-B"
S-1:15

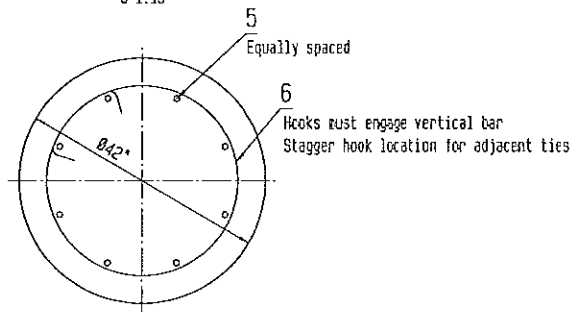

DETAIL "D"
S-1:2

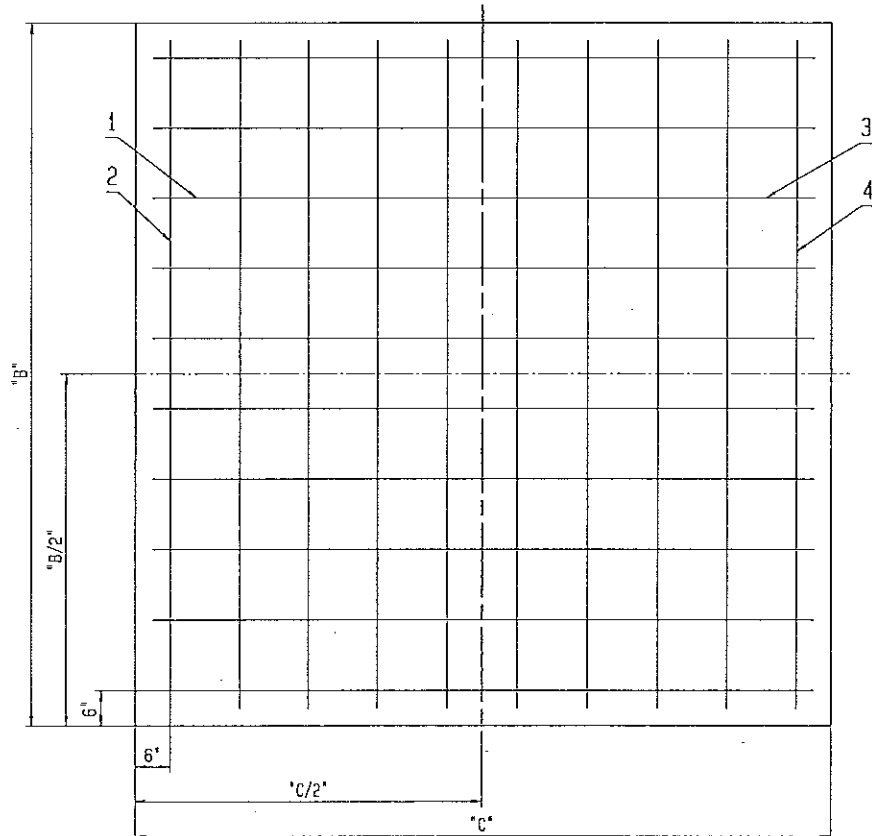

VIEW "C"
S-1:15

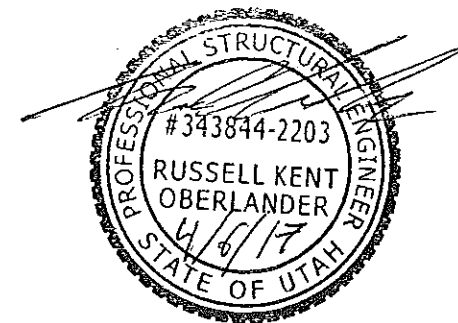
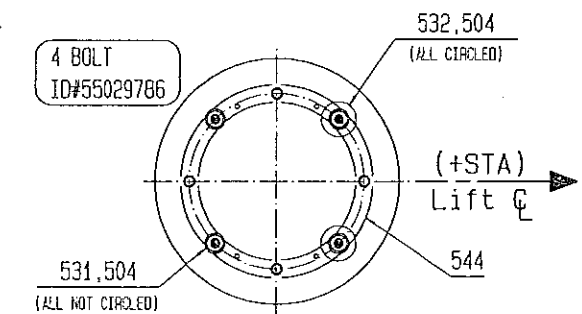
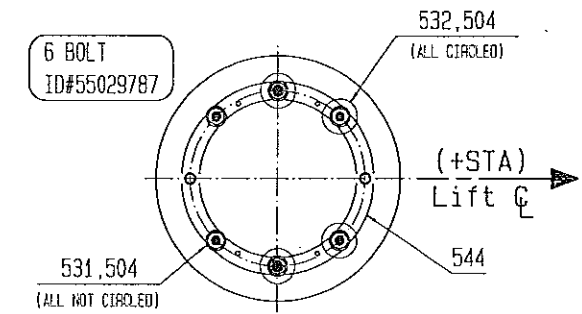
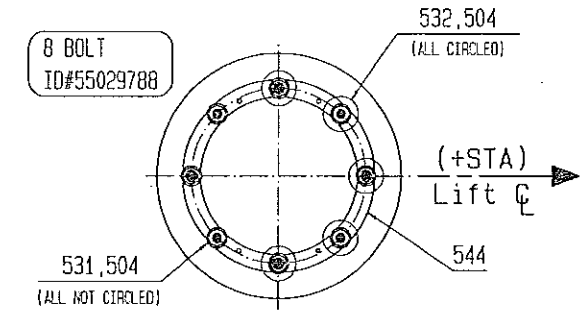
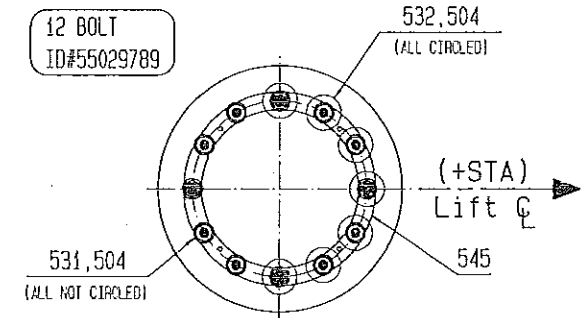

REV	DESCRIPTION	DATE	BY	CHK	SCALE	DATE	BY	CHK	
1	42RND, 12DEG, 12X30								
2	42RND, 12DEG, 8X30								
3	42RND, 12DEG, 6X30								
4	42RND, 12DEG, 4X30								
5	UPDATED SECTION "B-B" TO CLARIFY CIRCULAR TIE PLACEMENT	2016-07-01							
Doppelmayr						SCALE	DATE	BY	CHK
TWR FTR - SPREAD FOOTING 4-12 BOLT, 30 INCH BC, 12 DEG 42 INCH ROUND PEDESTAL						1/15	2017-04-07		
DRAWING NO. 90005285NAD005102									

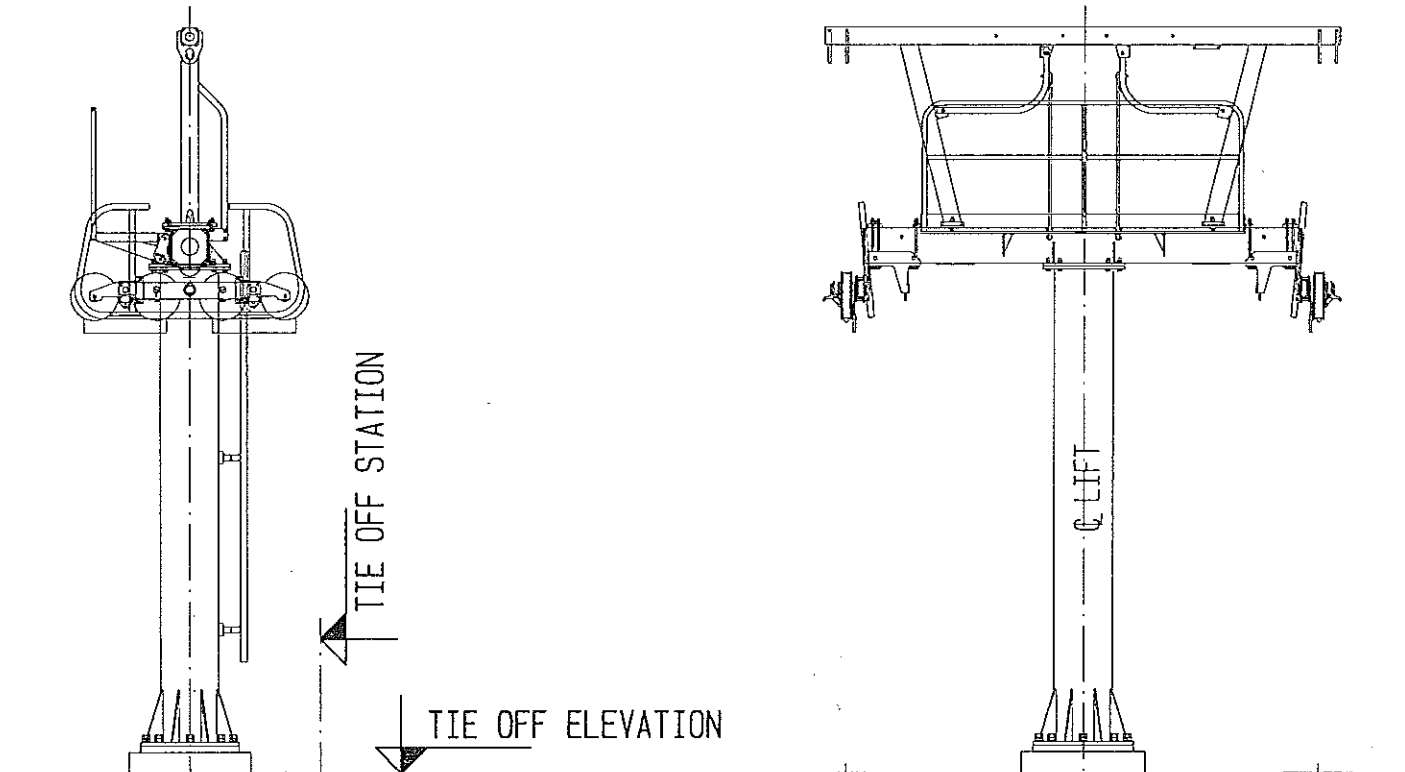

NOTES:
 -SOME TOWERS MAY REQUIRE TWO OR MORE SETS OF TIE OFF FOUNDATIONS.
 -IF OFFSET IS LISTED AS "-N/A-", NO TIE OFF FOUNDATION IS REQUIRED ON THAT SIDE OF THE TOWER AT THAT STATION.
 -TIE OFF DRAWINGS DETAIL HOOP, BAR, AND EMBEDMENTS FOR A SINGLE TIE OFF FOUNDATION.
 -IF TIE OFF FOUNDATION PAD INTERFERES WITH TOWER FOUNDATION, CONTACT ENGINEERING FOR ALTERNATIVE DESIGN.
 -TIE OFF FOUNDATIONS INCORPORATED INTO TOWER FOUNDATIONS ARE LISTED AS "-INC-" AND ARE DETAILED ON THE TOWER FOUNDATION DRAWINGS.

TWR NO.	TIE OFF STATION	TIE OFF ELEVATION	OFFSET LEFT	OFFSET RIGHT	TIE OFF ID NO.
1	1+95.5	6528.0	9'-2 1/2"	9'-2 1/2"	55053051
1	2+09.3	6528.1	9'-2 1/2"	9'-2 1/2"	55053051
5	12+84.2	6761.1	9'-2 1/2"	9'-2 1/2"	55019640
6	16+56.8	6877.0	9'-2 1/2"	9'-2 1/2"	55019640
10	29+60.8	7356.1	9'-2 1/2"	9'-2 1/2"	55019640

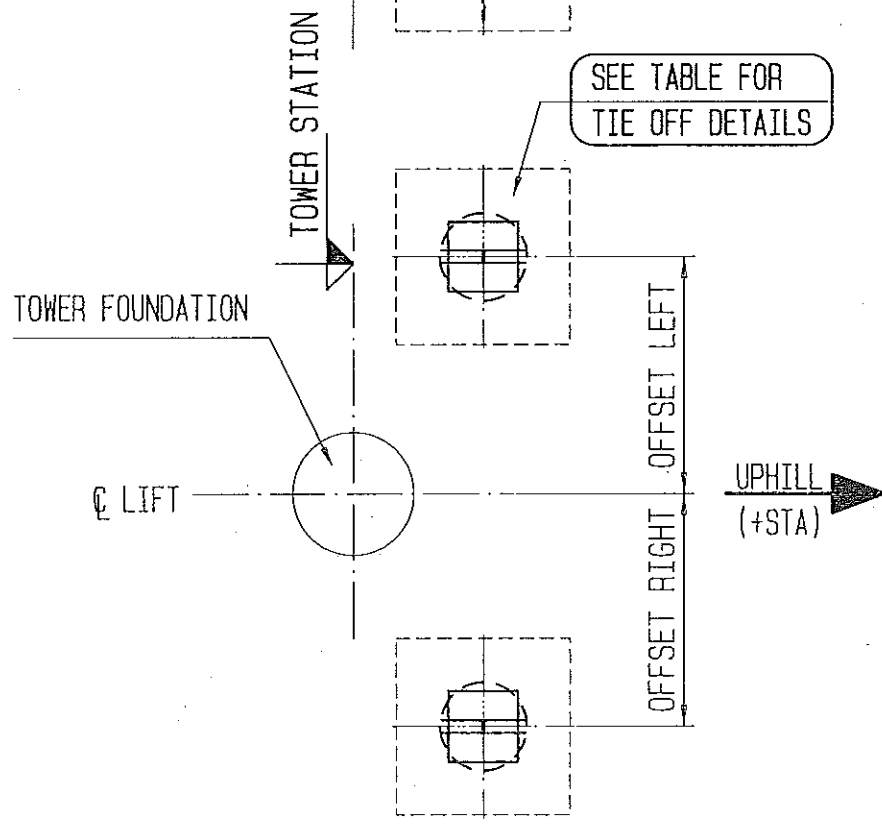
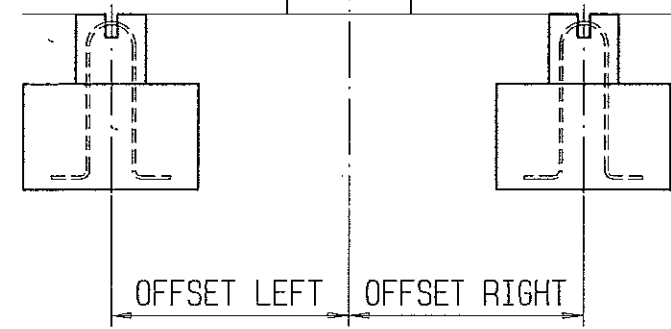

SEE TABLE FOR TIE OFF DETAILS

*TIE OFF FOUNDATION FOR THIS TOWER IS OPTIONAL.
 -T1 LOAD, NOMINAL TENSION, BARE CABLE = 10,600 LBF.
 -T5 LOAD, NOMINAL TENSION, BARE CABLE = 1,000 LBF.
 -T6 LOAD, NOMINAL TENSION, BARE CABLE = 3,700 LBF.
 -T10 LOAD, NOMINAL TENSION, BARE CABLE = 3,300 LBF.

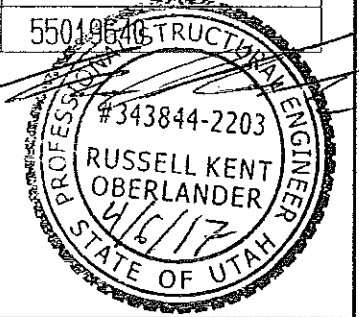

55051673

INDEX	REVISION	DATE	NAME	CONFIGURATION	SCALE	DATE	NAME
			Doppelmayr USA, Inc. 3160 West 500 South Salt Lake City UT 84104	0-Class: 0	1/60	2017-02-02	Fuhrken Lee
INSTALLATION: SNOWBASIN / WILDCAT					MASS	PLOTTED	
ORDER: SAA0002518					kg	2017-04-07	
TIE OFF FOUNDATION LAYOUT					16 Id: 55051673		
6-CLD 5.6M LINE GA.					DRAWING NO. 90007826NAD005102		

This drawing is intellectual property of Doppelmayr USA, Inc. This Drawing or information is our property and must not be copied nor utilized in whole or in part without permission and is subject to return upon request.

WHERE SITE CONDITIONS MAKE CONSTRUCTION IMPRACTICAL CONTACT ENGINEERING FOR ALTERNATIVE DESIGN.

- NOTES:
- Dimensions are not critical. Each installation must contain 2.3 cubic yards of concrete.
 - Concrete and steel must remain level or slightly below grade.
 - All rebar shall be ASTM A615 (60 KSI) or G400 metric.
 - All rebar dimensions shown are out to out.
 - All rebar shall be bent in accordance with ACI 318-14.
 - All rebar splices shall be in accordance with ACI 318-14.
 - See Tie Off Foundation Schedule for foundation location.
 - For general specifications see 90001186NAD005103.
 - Minimum concrete cover = 3".

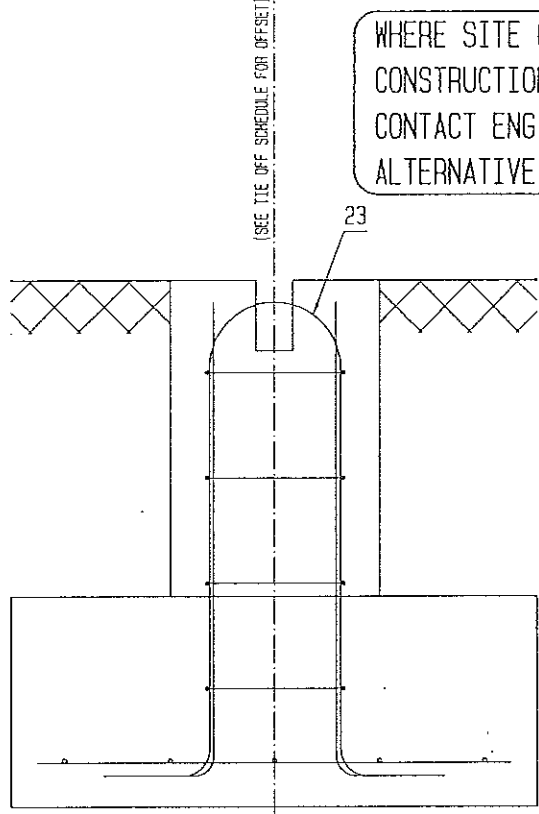
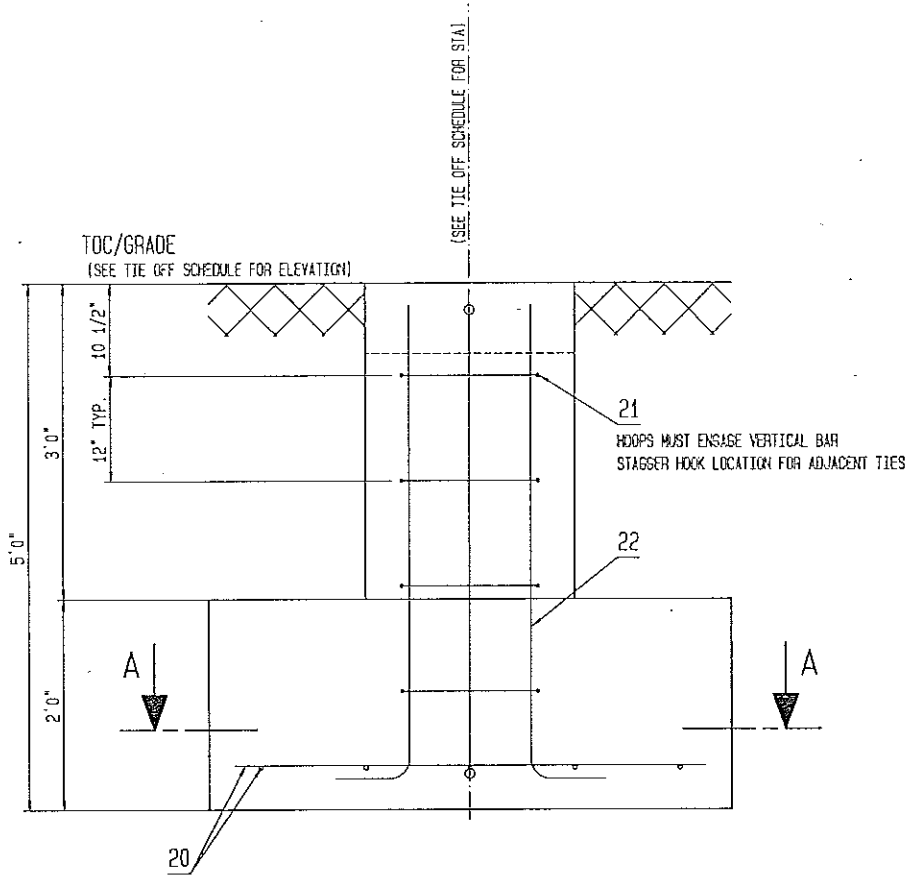

SECTION "A-A"

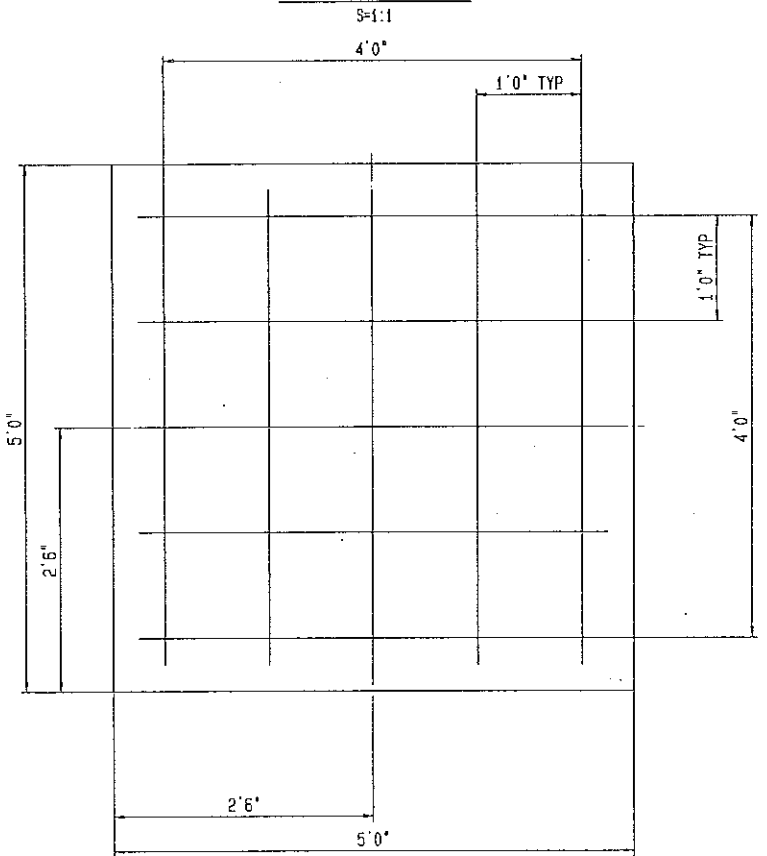

DETAIL "PED"

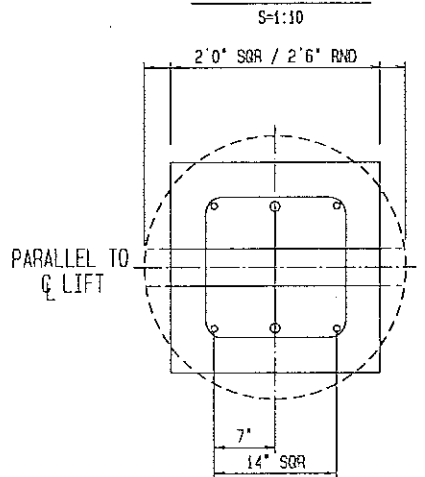

DETAIL "NOTCH"

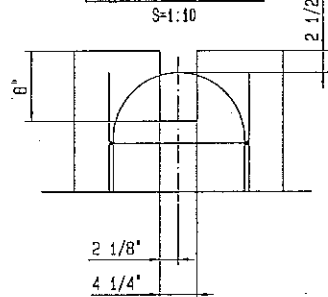

shape	item	quant	Ø	length
STRAIGHT	20	10	#4	4'6"
	21	4	#3	5'10"
	22	4	#6	5'6"
	23	1	#9	11'5"

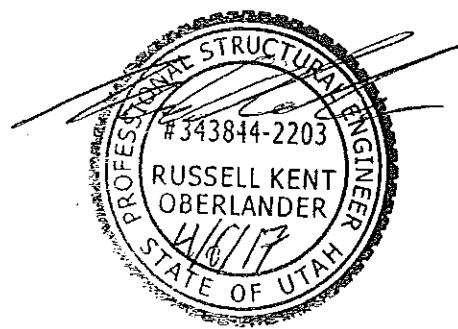

DATE	2016-07-14	BY	FAVOR LIM
DATE	2012-03-28	BY	FAVOR LIM
SCALE	1/10	DATE	2017-04-07
PROJECT	TIE OFF FOUNDATION	DATE	2017-04-07
DESCRIPTION	5X5X2 PAD WITH 2FT DIA/SSR PED	DATE	2017-04-07
PROJECT NO.	90001467NAD005102	DATE	2017-04-07

WHERE SITE CONDITIONS MAKE CONSTRUCTION IMPRACTICAL CONTACT ENGINEERING FOR ALTERNATIVE DESIGN.

- NOTES:
- Dimensions are not critical. Each installation must contain 1.6 cubic yards of concrete.
 - Concrete and steel must remain level or slightly below grade.
 - All rebar shall be ASTM A615 (60 KSI) or G400 metric.
 - All rebar dimensions shown are out to out.
 - All rebar shall be bent in accordance with ACI 318-14.
 - All rebar splices shall be in accordance with ACI 318-14.
 - See Tie Off Foundation Schedule for foundation location.
 - For general specifications see 90001186NAD005103.
 - Minimum concrete cover = 3".

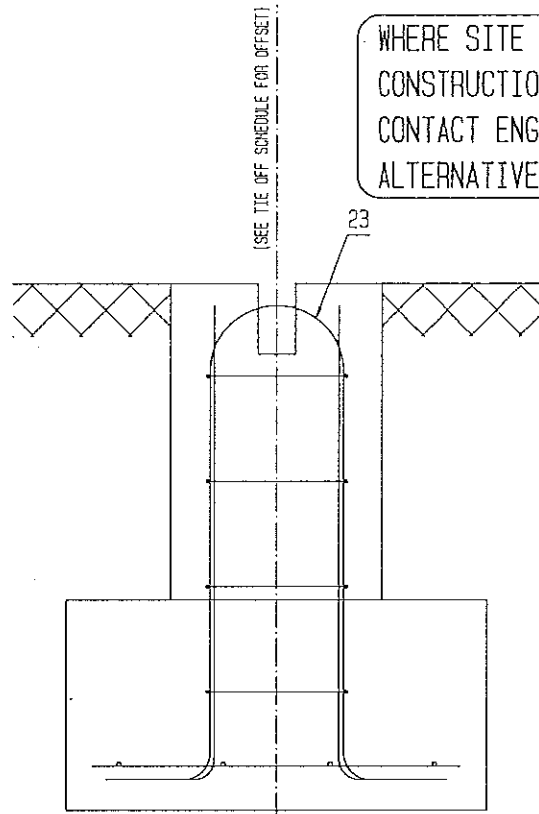
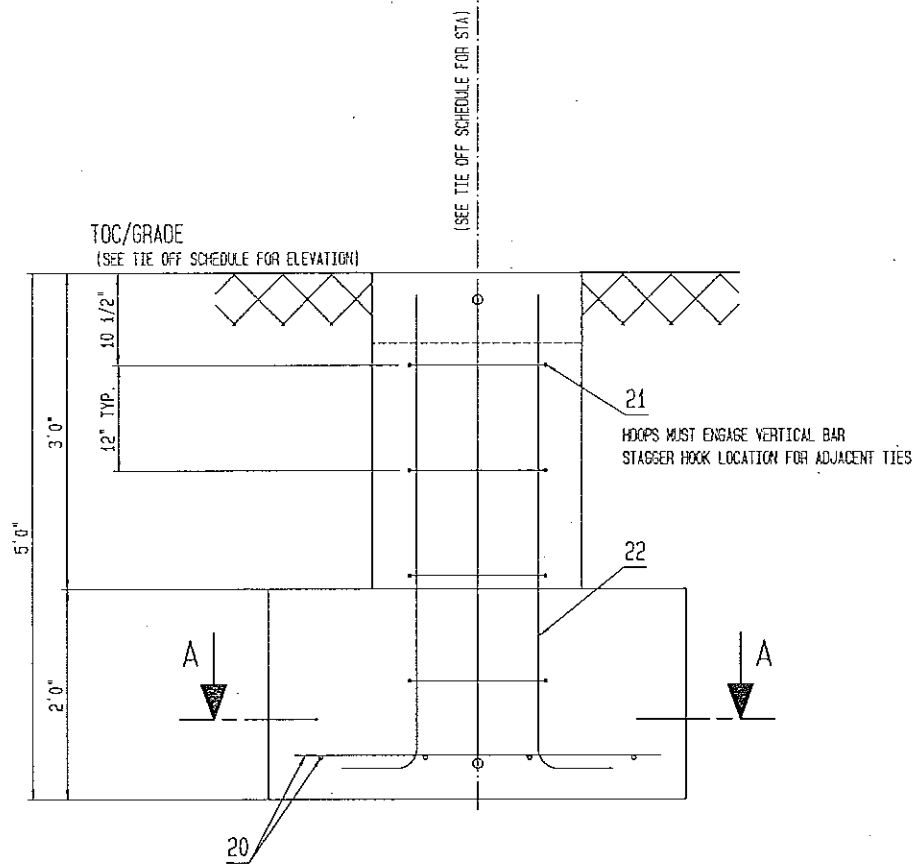

SECTION "A-A"
S=1:1

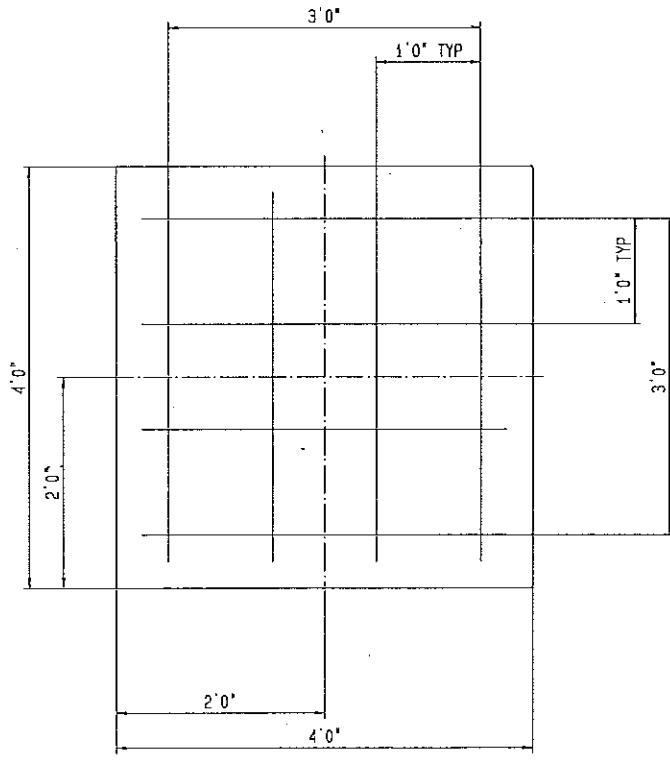

DETAIL "PED"
S=1:10

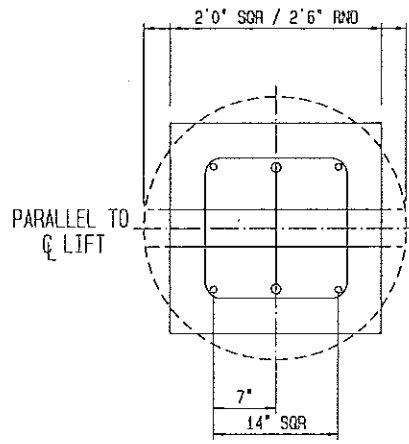

DETAIL "NOTCH"
S=1:10

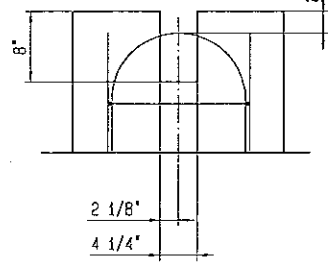

shape	item	quant	Ø	length
STRAIGHT	20	8	#4	3'6"
	21	4	#3	5'10"
	22	4	#6	5'6"
	23	1	#9	11'5"

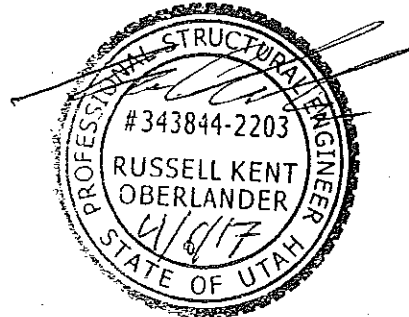

REVISED	DATE	BY	DESCRIPTION	SCALE	DATE	NAME
0	2017-04-07			1/10	2017-04-07	
PROJECT			TIE OFF FOUNDATION			
DESCRIPTION			4X4X2 PAD WITH 2FT DIA/SQR PED			
DRAWING NO.			90001468NAD005102 b			

CONCRETE SPECIFICATIONS:

1. CONCRETE WORK SHALL BE DONE IN ACCORDANCE WITH THE DOPPELMAYR DOCUMENT, 'Doppelmayr USA Specifications for Cast-in-place Concrete and Grout'.

GROUT SPECIFICATIONS:

1. GROUT UNDER BASE PLATES SHALL MEET OR EXCEED THE MINIMUM REQUIREMENTS AS DESCRIBED IN 'Doppelmayr CTEC US Concrete Specifications for Cast-in-place Concrete and Grout'. SEE THE DETAILS SHOWN BELOW FOR FINISHING REQUIREMENTS.

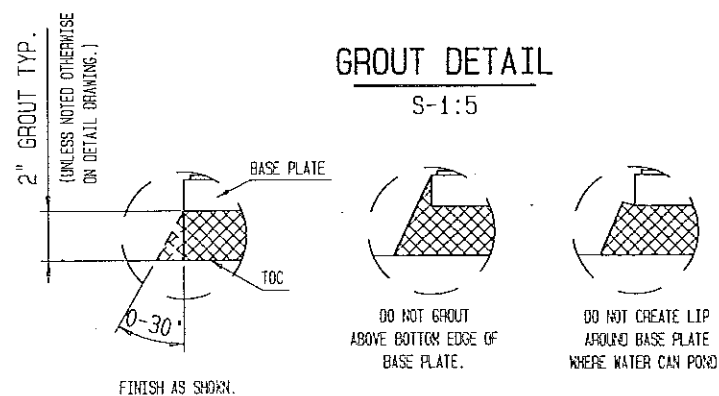

GROUNDING DETAILS:

GROUNDING PROCEDURE FOR NEW FOUNDATIONS (TOWER/TERMINAL)

1. LAY NO LESS THAN 20 FT OF #4 BARE COPPER WIRE IN STRAIGHT LINES (AS SHOWN) BENEATH FOUNDATION, AND IN DIRECT CONTACT WITH EARTH.
2. PRIOR TO POUR, RUN GROUNDING WIRE UP THE INSIDE OF THE REBAR CAGE AND TIE TO THE DOWN HILL ANCHOR BOLT.
3. COVER GROUNDING WIRE WITH 6-MIL POLYETHYLENE, TAR PAPER, OR OTHER NON ORGANIC MATERIAL TO PREVENT CONCRETE FROM PENETRATING BETWEEN THE WIRE AND THE EARTH.
4. AFTER STEEL PLACEMENT, USE GROUNDING LUG AND BOLT TO CONNECT WIRE TO THE DOWN HILL GUSSET AS SHOWN IN DETAIL 'Grounding'.

"Grounding"

S-1/2.5

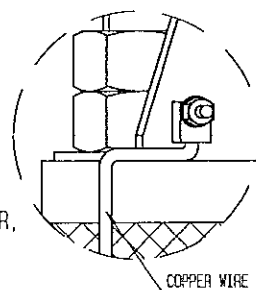

GROUNDING PROCEDURE FOR RETROFIT FOUNDATIONS (TOWER/TERMINAL)

1. IF EXISTING FOUNDATION HAS GROUNDING WIRE, UTILIZE EXISTING.
2. EXISTING FOUNDATIONS WHICH REQUIRE GROUNDING RETROFIT SHALL BE GROUNDING BY MEANS OF A GROUNDING ROD. DRIVE 3/4 INCH DIAMETER GROUNDING ROD 10FT INTO EARTH. USE GROUNDING LUGS TO CONNECT ONE END OF A #4 BARE COPPER WIRE TO THE UPHILL GUSSET (AS SHOWN IN "Grounding") AND THE OTHER END TO THE GROUNDING ROD.

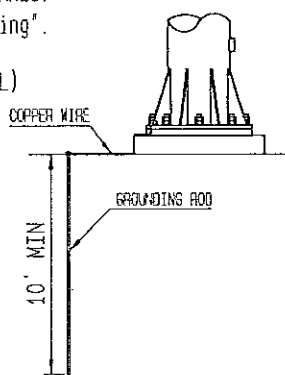

TORQUE TABLE

BOLT DIAMETER	TORQUE (LBF*FT)	TORQUE (N*M)
1 1/4	600	814
1 1/2	750	1017
1 3/4	1300	1763
2	2065	2800

LEVELING PROCEDURES:

LEVELING PROCEDURE WITH LEVELING NUTS ON ANCHOR (SEE "Leveling Nut")

1. PLACE LEVELING NUTS AND WASHERS ON CORNER ANCHOR BOLTS AND ADJUST TO PLUMB.
2. SET STEEL AND SECURE IN PLACE WITH WASHERS AND NUTS AS SHOWN ON THE CONSTRUCTION DRAWINGS.
3. APPLY NON-SHRINKING GROUT BETWEEN BASE PLATE AND FACE OF CONCRETE, LEAVING A LARGE ENOUGH VOID TO BACK OFF LEVELLING NUTS. GROUT IS NOT REQUIRED IN CENTER UNDER TUBES.
4. AFTER GROUT CURES, LOWER LEVELING NUTS.
5. GROUT VOIDS AROUND LEVELING NUTS.
6. TORQUE NUTS OF ALL ANCHORS TO THE VALUE LISTED IN TORQUE TABLE.
7. TORQUE ALL TOP NUTS TO 400 LBF*FT [542 N*m]

LEVELING PROCEDURE WITH LEVELING NUTS ON TEMPLATE (SEE "Leveling Nut2")

1. ADJUST LEVELING NUTS ON TEMPLATE TUBES TO SPEC'D GROUT HEIGHT.
2. SET STEEL AND SECURE IN PLACE WITH WASHERS AND NUTS AS SHOWN ON THE CONSTRUCTION DRAWINGS, ADJUST LEVELING NUTS TO ALIGN STRUCTURE.
3. APPLY NON-SHRINKING GROUT BETWEEN BASE PLATE AND FACE OF CONCRETE. GROUT IS NOT REQUIRED IN CENTER UNDER TUBES.
4. AFTER GROUT CURES, TORQUE BOTTOM NUTS OF ALL ANCHORS TO THE VALUE LISTED IN TORQUE TABLE.
5. TORQUE ALL TOP NUTS TO 400 LBF*FT [542 N*m]

LEVELING PROCEDURE WITH SHIMS (SEE "Shims")

1. STACK SHIMS ON ANCHOR BOLTS AND LEVEL.
2. SET STEEL AND SECURE IN PLACE WITH WASHERS AND NUTS AS SHOWN ON THE THE CONSTRUCTION DRAWINGS.
3. TORQUE THE BOTTOM NUTS OF ALL ANCHOR BOLTS TO THE VALUE LISTED IN THE TORQUE TABLE.
4. TORQUE ALL TOP NUTS TO 400 LBF*FT [542 N*m].
5. APPLY GROUT BETWEEN BASE PLATE AND FACE OF CONCRETE TO LOCK SHIMS IN PLACE. GROUT IS NOT REQUIRED IN CENTER UNDER TUBES.

"Leveling Nut"

S-1:5

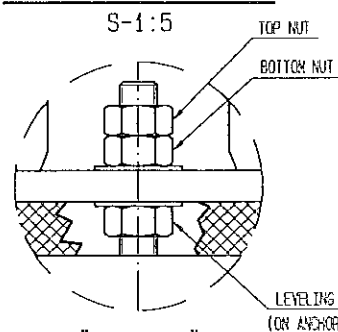

"Leveling Nut2"

S-1:5

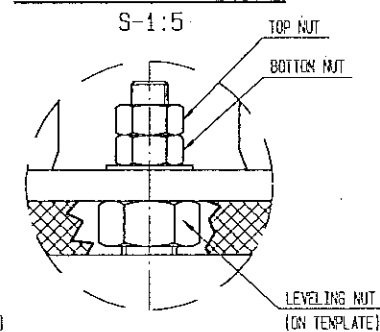

"Shims"

S-1:5

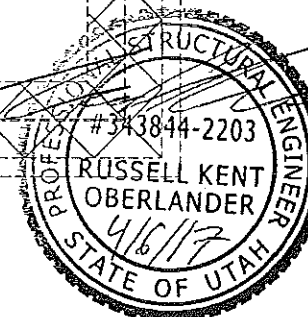
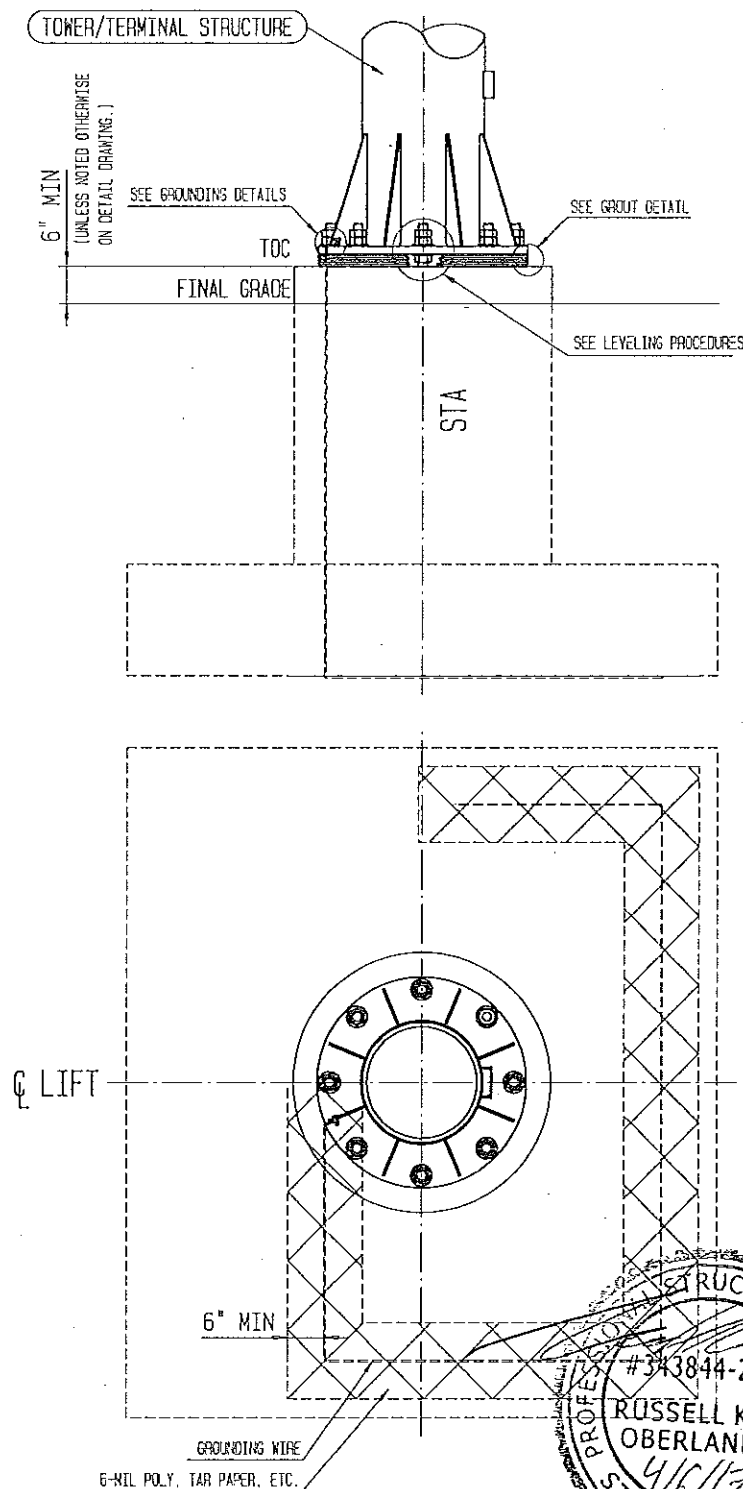
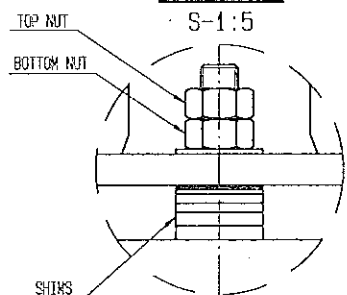

REVISED	ADDED LEVELING PROCEDURE WITH LEVELING NUTS ON TEMPLATE	2016-11-26	Fuhrken Lee	55052020
DATE	NAME	DATE	NAME	SCALE
2016-11-26	Fuhrken Lee	2016-11-29	Fuhrken Lee	1/20
DATE	NAME	DATE	NAME	SCALE
2017-02-24/14:16:45	Fuhrken Lee	2017-04-07	Fuhrken Lee	1/20
DATE	NAME	DATE	NAME	SCALE
2017-04-07	Fuhrken Lee	2017-04-07	Fuhrken Lee	1/20
DATE	NAME	DATE	NAME	SCALE
2017-04-07	Fuhrken Lee	2017-04-07	Fuhrken Lee	1/20
DATE	NAME	DATE	NAME	SCALE
2017-04-07	Fuhrken Lee	2017-04-07	Fuhrken Lee	1/20