



908 WEST GORDON AVE. SUITE #201
LAYTON, UT 84041
(801) 547-8133

February 13, 2017

FIRST REVIEW
WC³ Project #: 217-525-008

Weber County
Building Inspection Department
2380 Washington Boulevard, Suite 240
Ogden, Utah 84401
Phone: (801) 399-8374

Attention: Craig Browne, Building Official

Subject: Summit Powder Mtn Townhomes – Plan Review Comments

Mr. Browne:

West Coast Code Consultants, Inc. (WC³) has completed the first review of the proposed Summit Powder Mtn Townhomes project located in Eden, UT. This review was based upon the following:

1. Architectural drawings dated 1/26/2017 by Studio MA, sealed and signed by Daniel Hoffman, Licensed Architect.
2. Structural drawings and calculations dated 1/24/2017 by Rudow & Berry, Inc., sealed and signed by Mark A Rudow, Professional Engineer.
3. Mechanical and plumbing drawings dated 1/26/2017 by Studio MA, sealed and signed by Henry W Johnstone, Professional Engineer.
4. Electrical drawings dated 1/24/2017 by Studio MA, sealed and signed by Theodore C Moeller, Professional Engineer.

The 2015 International Codes and 2014 NEC, as adopted by the State of Utah, were used as the basis of our review. Specific comments in regards to this project are enclosed with this cover letter. If you have any questions in regards to this review please do not hesitate to contact me.

Sincerely,

Mike Molyneux, P.E.

Attachment: Comments

Plan Review Comments

Project Name: Summit Powder Mtn Townhomes

Code Review by: Jason vonWeller

Location(s): 5731-5747 North Cooper Crest, Eden, UT

Structural by: Mike Molyneux

OCCUPANCY & BUILDING SUMMARY:

Type of Construction	Use Group(s)	Occupant Load	Risk Category	Square Footage	Building Height	Sprinklers
VB	R3	*	II	3159(3) 4149(1) ft ²	2-story, 25-feet	13R

* - Items noted with an asterisk may change as a result of the plan review comments.

GENERAL INFORMATION:

The submitted documents for the above-mentioned project, as outlined in the cover letter, have been reviewed. The following comments address areas of concern, non-compliance with the governing code, potential errors, or omissions in the proposed design. The appropriate design professional must address each comment below and submit a written response in addition to revised plans and calculations if necessary. **Please cloud any revisions made to the construction drawings and provide the date of the latest revision on each revised sheet.**

CODE REVIEW COMMENTS:

- A1. Sheet S3.11: As a matter of consideration for field practices, it is this reviewer's opinion that these highlighted details below are extremely difficult to correctly apply in the field. Typical field practices don't allow for j-bolts and horizontal re-enforcing bar extensions mid-wall or below top of form because it would become necessary for the foundation contractor to cut or drill the forms. The design and installation is not ipso facto against code and no correction is required, but it would serve well, if these details do remain, to note that drilling and epoxying require special inspection and test on all anchors installed post foundation casting.

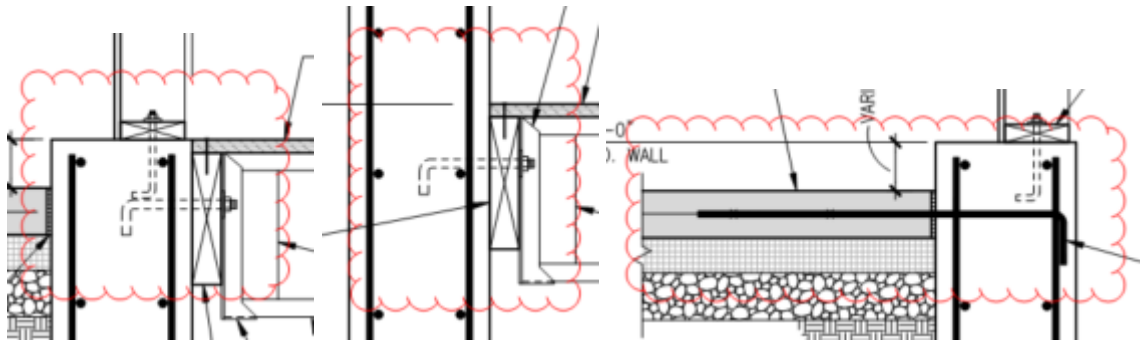

- A2. Please clearly indicate on the plans the requirements for safety glazing and where it is to be provided. IRC R308.4 requires that all shower compartments, sliding glass doors, windows adjacent to doors, and other hazardous areas have safety glazing.
- A3. Please provide details and dimensions for stairs, including rise and run dimensions.



- A4. Please provide details and dimensions for guardrails to be provided at the interior and exterior stairs, and at the edge of the exterior deck. Guards should meet the minimum requirements of IRC R312.1.
- A5. Please show on the plans how the building address will be listed as required by IRC R319.1.
- A6. Provide notes or details on the plans showing the required separation between the garage and the dwelling with a minimum of ½ inch gypsum board as required by IRC R302.6, and 5/8 type X at the ceiling where living space is located above the garage.

MECHANICAL REVIEW COMMENTS:

- M1. Indicate on the plans the length of the clothes dryer vent. Verify that it will meet the requirements of IRC M1502.4.4.1 as amended by the State of Utah.
- M2. Please provide details/cut sheets on fireplaces in order to determine code compliance.

PLUMBING REVIEW COMMENTS:

- P1. Indicate on the plans the maximum flow rates for the shower heads, lavatory and sink faucets, and water closets. Flow rates should meet requirements of IRC P2903.2.
- P2. Indicate on the plans that hose bibs shall be provided with an atmospheric or pressure type vacuum breaker per IRC P2902.4.3.

ELECTRICAL REVIEW COMMENTS:

- E1. Sheet E1.23: Dishwasher branch circuit shall be GFCI protected E3902.10
- E2. Sheet E1.23: Receptacles serving kitchen counter tops shall be installed per E3901.4
- E3. Sheet E1.22: CO detectors shall be located per R315.3
- E4. Please note that all receptacles will be tamper resistant.
- E5. All receptacles serving bedrooms shall be Arc-Fault protected. E3902.16
- E6. Receptacles located in unfinished basement locations shall be GFCI protected per E3902.5.

ENERGY REVIEW COMMENTS:

No Comments

STRUCTURAL COMMENTS:

Structural Drawings:

- S1. Please provide the geotechnical report by IGES referenced in the plans for further review.
- S2. Sheet s0.12: The Simpson strap schedule has not been provided with marks as shown on the plans. Please address.
- S3. Sheet s0.13: The special inspection requirements shown are per the 2009 IBC. Significant changes have been made to the special inspection requirements especially the steel inspections per Section N5.4 of AISC 360-10. Please address.



- S4. Sheet s1.21: The footing calculations (page 333) for SW-5 show that a 3.67 foot wide footing is required while the drawings show a WF3 which is a 3-foot wide footing. Please coordinate.
- S5. Sheet s1.23: Please address the following...
- A. Detail 5/s4.14 is shown at gridline B at the entry level. This detail has not been provided. Please address.
 - B. Beam TH11 at the entry level does not match what is shown in the calculations. The calculations show 6-3/4x10-1/2 glu-lam beam while the drawings show a 6-3/4x9 glu-lam beam. Please address.
- S6. Sheet s1.24: Please provide the size of the header near beam FB8 that is supporting FB10. This is not shown in the plans or detail 1/s4.14.
- S7. Sheet s4.10: Multiple floor framing details reference a Simpson hanger per schedule. Please clarify where this schedule can be found on the plans.
- S8. Sheet s4.13: Detail 9 does not show endwall blocking at the floor joists which run parallel to the foundation walls. Please provide a detail showing the blocking requirements as required by Section 12.11.2.2 of ASCE 7-10.

Structural Calculations:

- S9. There is a nonparallel irregularity as defined in Table 12.3-1 of ASCE 7-10. This occurs at the end unit. Please address.
- S10. The beam calculations are per the 2012 IBC and 2012 NDS. Please verify that the calculations meet the requirements of the 2015 IBC and all referenced standards.
- S11. Please clarify the lateral calculations. Please address the following:
- A. Please clarify whether the simplified or equivalent lateral force method was used.
 - B. Please show how the forces at each level were determined (vertical distribution of forces, etc. as applicable).
 - I. Calculations for Unit 62R show the vertical distribution of forces. Please provide for the other units.
- S12. The roof snow load is listed as 263psf. Please confirm that a percentage of the snow was considered in the seismic weight of the structure as required by Section 1605.3.1 and 1605.3.2 of the Utah Amended Code

If you have any questions regarding the above comments, please contact Mike Molyneux at mikem@wc-3.com or by phone at (801) 547-8133.

[END]