

# Sun Crest Meadows Subdivision Phase 1

Weber County, Utah

A Part of the Northwest Quarter of Section 32,  
Township 6 North, Range 2 West, Salt Lake Base & Meridian

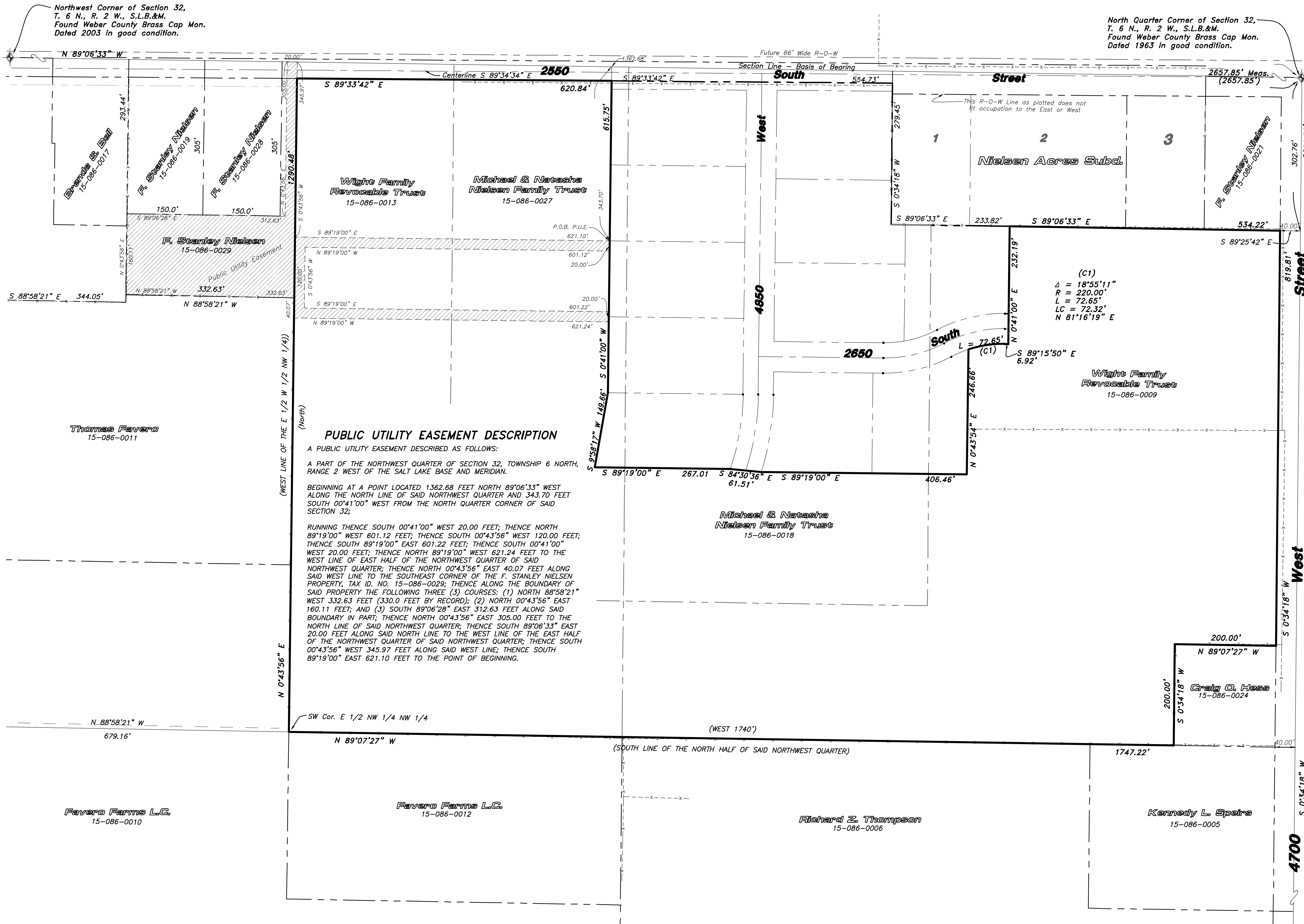

Northwest Corner of Section 32,  
T. 6 N., R. 2 W., S.L.B.&M.  
Found Weber County Brass Cap Mon.  
Dated 2003 in good condition.

North Quarter Corner of Section 32,  
T. 6 N., R. 2 W., S.L.B.&M.  
Found Weber County Brass Cap Mon.  
Dated 1963 in good condition.

## SURVEYOR'S CERTIFICATE

I, K. Greg Hansen, do hereby certify that I am a Registered Professional Land Surveyor in the State of Utah in accordance with Title 58, Chapter 22, Professional Engineers and Land Surveyors Act; and I have completed a Survey of the property described on this plat in accordance with Section 17-23-17 and have verified all measurements, and have placed monuments as represented on this plat, and have hereby subdivided said tract into eleven (11) lots, known hereafter as Sun Crest Meadows Subdivision Phase 1 in Weber County, Utah, and has been correctly drawn to the designated scale and is true and correct representation of the herein described lands included in said Subdivision, based upon data compiled from records in the Weber County Recorder's Office and from said survey made by me or under my supervision on the ground. I further hereby certify that the requirements of all applicable statutes and ordinances of Weber County Concerning Zoning Requirements regarding lot measurements have been complied with.

Signed this \_\_\_\_\_ day of \_\_\_\_\_, 2018.

K. Greg Hansen P.L.S.  
Utah Land Surveyor License No. 167819



## BOUNDARY DESCRIPTION

A PART OF THE NORTHWEST QUARTER OF SECTION 32, TOWNSHIP 6 NORTH, RANGE 2 WEST OF THE SALT LAKE BASE AND MERIDIAN.

BEGINNING AT THE SOUTHEAST CORNER OF THE F. STANLEY NIELSEN PROPERTY FILED AS ENTRY NO. 2822142 IN THE WEBER COUNTY RECORDER OFFICE, BEING A POINT LOCATED 302.76 FEET SOUTH 00°34'18" WEST ALONG THE EAST LINE OF SAID NORTHWEST QUARTER AND 40.00 FEET NORTH 89°25'42" WEST FROM THE NORTHEAST CORNER OF SAID NORTHWEST QUARTER;

RUNNING THENCE SOUTH 00°34'18" WEST 819.81 FEET (817 FEET BY RECORD) ALONG SAID WEST RIGHT-OF-WAY LINE TO THE NORTHEAST PROPERTY CORNER OF THE CRAIG O. HESS PROPERTY, FILED AS ENTRY NO. 1122274 IN THE FILES OF THE WEBER COUNTY RECORDER; THENCE ALONG THE BOUNDARY LINE OF SAID HESS PROPERTY THE FOLLOWING TWO (2) COURSES; (1) NORTH 89°07'27" WEST 200.00 FEET; AND (2) SOUTH 00°34'18" WEST 200.00 FEET TO THE SOUTH LINE OF THE NORTH HALF OF SAID NORTHWEST QUARTER BEING A POINT ON THE NORTH BOUNDARY LINE OF THE KENNEDY L. SPEIRS PROPERTY, FILED AS ENTRY NO. 2814936; THENCE NORTH 89°07'27" WEST 1747.22 FEET (WEST 1740 FEET BY RECORD) ALONG SAID SOUTH BOUNDARY LINE TO THE SOUTHWEST CORNER OF THE EAST HALF OF THE NORTHWEST QUARTER OF SAID NORTHWEST QUARTER; THENCE NORTH 00°43'56" EAST 1290.48 FEET ALONG THE WEST LINE OF SAID EAST HALF TO THE SOUTH RIGHT-OF-WAY LINE OF 2550 SOUTH STREET; THENCE ALONG SAID SOUTH RIGHT-OF-WAY LINE SOUTH 89°33'42" EAST 620.84 FEET; THENCE SOUTH 00°41'00" WEST 615.75 FEET; THENCE SOUTH 09°58'17" WEST 149.66 FEET; THENCE SOUTH 89°19'00" EAST 267.01 FEET; THENCE SOUTH 84°30'36" EAST 61.51 FEET; THENCE SOUTH 89°19'00" EAST 406.46 FEET; THENCE NORTH 00°43'54" EAST 246.66 FEET; THENCE IN A EASTERLY DIRECTION TO THE RIGHT OF A NON-TANGENT 220.00 FOOT CURVE, A DISTANCE OF 72.65 FEET, CHORD BEARS NORTH 81°16'19" EAST 72.32 FEET, HAVING A CENTRAL ANGLE OF 18°55'11"; THENCE SOUTH 89°15'50" EAST 6.92 FEET; THENCE NORTH 00°41'00" EAST 232.19 FEET TO THE SOUTH BOUNDARY LINE OF NIELSEN ACRES SUBDIVISION FILED AS ENTRY NO. 1637888; THENCE ALONG THE SOUTH BOUNDARY LINE OF SAID NIELSEN ACRES SUBDIVISION AND THEN SAID F. STANLEY NIELSEN PROPERTY SOUTH 89°06'33" EAST 534.22 FEET TO THE POINT OF BEGINNING. CONTAINING 40.07 ACRES.

## PUBLIC UTILITY EASEMENT DESCRIPTION

A PUBLIC UTILITY EASEMENT DESCRIBED AS FOLLOWS:

A PART OF THE NORTHWEST QUARTER OF SECTION 32, TOWNSHIP 6 NORTH, RANGE 2 WEST OF THE SALT LAKE BASE AND MERIDIAN.

BEGINNING AT A POINT LOCATED 1362.68 FEET NORTH 89°06'33" WEST ALONG THE NORTH LINE OF SAID NORTHWEST QUARTER AND 343.70 FEET SOUTH 00°41'00" WEST FROM THE NORTH QUARTER CORNER OF SAID SECTION 32;

RUNNING THENCE SOUTH 00°41'00" WEST 20.00 FEET; THENCE NORTH 89°19'00" WEST 801.12 FEET; THENCE SOUTH 00°43'56" WEST 120.00 FEET; THENCE SOUTH 89°19'00" EAST 601.22 FEET; THENCE SOUTH 00°41'00" WEST 20.00 FEET; THENCE NORTH 89°19'00" WEST 621.24 FEET TO THE WEST LINE OF EAST HALF OF THE NORTHWEST QUARTER OF SAID NORTHWEST QUARTER; THENCE NORTH 00°43'56" EAST 40.07 FEET ALONG SAID WEST LINE TO THE SOUTHEAST CORNER OF THE F. STANLEY NIELSEN PROPERTY, TAX ID, NO. 15-086-0029; THENCE ALONG THE BOUNDARY OF SAID PROPERTY THE FOLLOWING THREE (3) COURSES: (1) NORTH 89°39'21" WEST 332.63 FEET (330.0 FEET BY RECORD); (2) NORTH 00°43'56" EAST 160.11 FEET; AND (3) SOUTH 89°06'28" EAST 312.63 FEET ALONG SAID BOUNDARY IN PART; THENCE NORTH 00°43'56" EAST 305.00 FEET TO THE NORTH LINE OF SAID NORTHWEST QUARTER; THENCE SOUTH 89°06'33" EAST 20.00 FEET ALONG SAID NORTH LINE TO THE WEST LINE OF THE EAST HALF OF THE NORTHWEST QUARTER OF SAID NORTHWEST QUARTER; THENCE SOUTH 00°43'56" WEST 343.97 FEET ALONG SAID WEST LINE; THENCE SOUTH 89°19'00" EAST 621.10 FEET TO THE POINT OF BEGINNING.

(C1)  
Δ = 18°55'11"  
R = 220.00'  
L = 72.65'  
LC = 72.32'  
N 81°16'19" E

- ### LEGEND
- Subject Property Line
  - - - Interior Lot Lines
  - - - Adjoining Property Line
  - - - Previous Property Line
  - - - Centerline
  - - - Public Utility Easement (PUE)
  - - - Ditch
  - - - Field Separation Line
  - - - Fence Line (Wire)
  - - - Fence Line (wood or Vinyl)
  - Street Monument
  - Found rebar set by others
  - Set 5/8"x24" Rebar With Cap
  - Section Corner

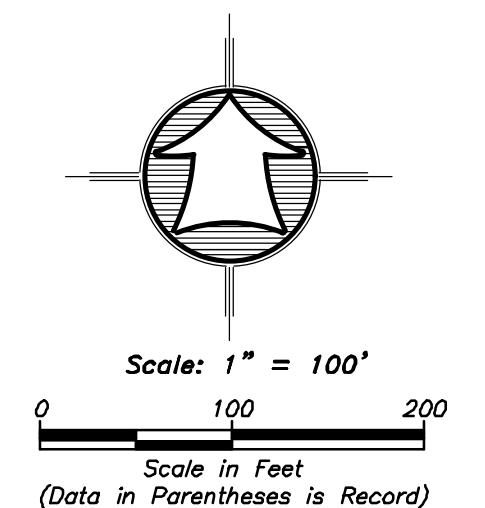

WEBER COUNTY RECORDER

ENTRY NO. \_\_\_\_\_ FEE PAID \_\_\_\_\_

FILED FOR RECORD AND RECORDED \_\_\_\_\_

IN BOOK \_\_\_\_\_ OF OFFICIAL RECORDS, PAGE \_\_\_\_\_ RECORDED FOR \_\_\_\_\_

COUNTY RECORDER

BY: \_\_\_\_\_ DEPUTY

**HANSEN & ASSOCIATES, INC.**  
Consulting Engineers and Land Surveyors  
538 North Main Street, Brigham, Utah 84302  
Visit us at [www.hansen.net](http://www.hansen.net)  
Brigham City Ogden Logan  
(435) 723-3491 (801) 399-4905 (435) 752-8272