

# JACQUELYN ESTATES CLUSTER SUBDIVISION PHASE 1, 1st AMENDMENT

A PART OF THE NORTHWEST QUARTER OF SECTION 29, T. 6 N., R. 2 W., S.L.B. & M.

WEBER COUNTY, UTAH

OCTOBER 2015

### OWNER'S DEDICATION

We the undersigned owners of the herein described tract of land, do hereby set apart and subdivide the same into lots and streets and Private Streets as shown hereon and name said tract JACQUELYN ESTATES CLUSTER SUBDIVISION PHASE 1 1st AMENDMENT.

We hereby grant and dedicate a perpetual right and easement over, upon and under the lands designated hereon as public utility, storm water detention pond(s), drainage easement(s), and canal maintenance easement(s), the same to be used for the installation maintenance and operation of public utility service line(s), storm drainage facilities, irrigation canal(s) or for the perpetual preservation of water channels in their natural state whichever is applicable and as may be authorized by the governing authority, with no buildings or structures being erected within such easements.

We hereby grant a Temporary Turnaround Easement as shown hereon, said easement shall terminate at such time as Jacquelyn Park Lane street is extended. The extension of said street shall constitute evidence of the termination of the easement and shall terminate, relinquish and/or extinguish without further documentation. Furthermore, the easement may be terminated at any time by the governing entity without the approval or acknowledgment of the underlying fee owner(s), whichever may occur first. The granting of this easement is intended for authorized use only in accordance with the governing entities needs or requirements and for the use of owners within this subdivision. No use by the general public shall constitute a statutory dedication to the public of the Temporary Turnaround Easement.

Signed this \_\_\_\_\_ day of \_\_\_\_\_ 20\_\_\_\_  
 Craig Standing - President CJ Homes.

### CORPORATE ACKNOWLEDGMENT

State of Utah )  
 County of \_\_\_\_\_ )  
 On this \_\_\_\_\_ day of \_\_\_\_\_, 2\_\_\_\_, personally appeared before me \_\_\_\_\_ whose identity is \_\_\_\_\_ (name of document signer) personally known to me (or proven on the basis of satisfactory evidence) and who by me duly sworn/affirmed, did say that he/she is the \_\_\_\_\_ of \_\_\_\_\_ (Name of Corporation) and that said document was signed by him/her in behalf of said Corporation by Authority of its Bylaws, or Resolution of its Board of Directors, and said \_\_\_\_\_ (name of document signer) acknowledged to me that said Corporation executed the same.

Notary Public

### BOUNDARY DESCRIPTION

ALL OF THAT COMMON AREA OF JACQUELYN ESTATES CLUSTER SUBDIVISION PHASE 1, BEING A PART OF THE NORTHWEST QUARTER OF SECTION 29, TOWNSHIP 6 NORTH, RANGE 2 WEST, SALT LAKE BASE AND MERIDIAN, U.S. SURVEY, MORE PARTICULARLY DESCRIBED AS FOLLOWS:  
 BEGINNING AT A POINT NORTH 89°02'15" WEST 742.78 FEET ALONG THE QUARTER SECTION LINE AND NORTH 0°57'45" EAST 33.00 FEET FROM THE CENTER OF SAID SECTION 29, AND RUNNING THENCE NORTH 89°02'15" WEST 585.31 FEET TO THE EAST R.O.W. LINE OF 4900 WEST STREET EXTENDED; THENCE NORTH 00°25'30" EAST 426.39 FEET ALONG SAID R.O.W. LINE OF 4900 WEST STREET; THENCE SOUTH 89°34'30" EAST 60.00 FEET; THENCE SOUTH 24°39'19" EAST 44.10 FEET; THENCE SOUTH 44°06'25" EAST 140.06 FEET; THENCE SOUTH 51°37'21" EAST 81.00 FEET; THENCE SOUTH 76°35'51" EAST 79.50 FEET; THENCE NORTH 7°38'15" EAST 116.00 FEET; THENCE EASTERLY ALONG THE ARC OF A 125.00 FOOT RADIUS CURVE TO THE LEFT A DISTANCE OF 10.04 FEET (DELTA IS 4°36'06") AND CHORD BEARS SOUTH 87°16'27" EAST 10.04 FEET; THENCE SOUTH 7°38'15" WEST 116.20 FEET; THENCE SOUTH 77°21'58" EAST 131.42 FEET; THENCE NORTH 89°38'46" EAST 40.25 FEET; THENCE SOUTH 43°05'00" EAST 89.40 FEET; THENCE SOUTH 41°37'05" EAST 41.40 FEET; THENCE SOUTH 0°57'45" WEST 101.00 FEET TO THE POINT OF BEGINNING.  
 CONTAINS 152,294 SqFt OR 3.496 ACRES.

CENTER OF SEC 29,  
 T6N, R2W, S18BM  
 FOUND WEBER CO MONUMENT  
 DATED 1963, FAIR CONDITION

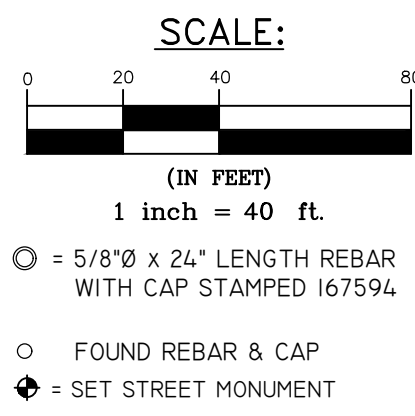
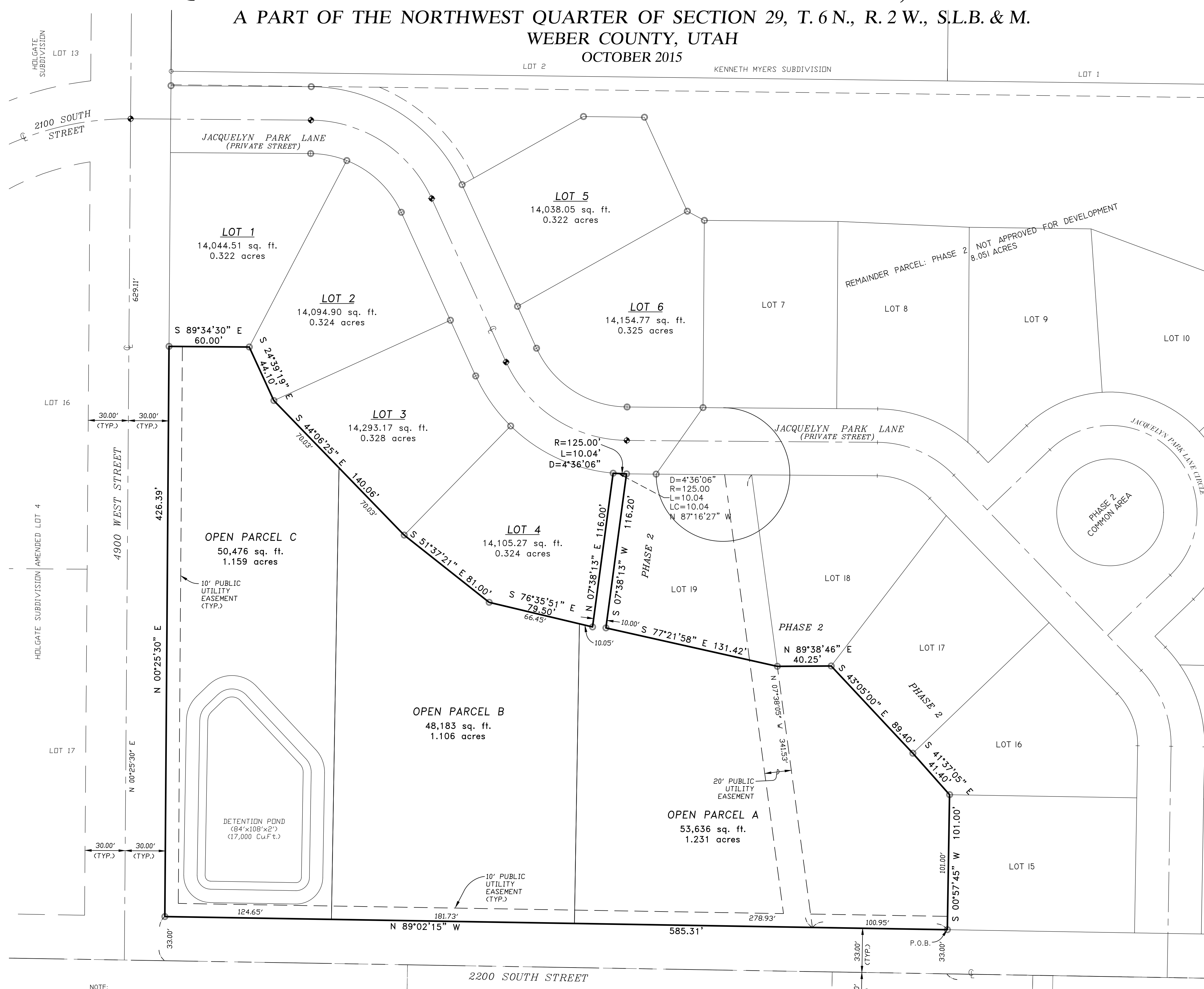

**WEBER COUNTY SURVEYOR**  
 I HEREBY CERTIFY THAT THE WEBER COUNTY SURVEYOR'S OFFICE HAS REVIEWED THIS PLAN FOR MATHEMATICAL CORRECTNESS, SECTION CORNER DATA, AND FOR HARMONY WITH LINES AND MONUMENTS ON RECORD IN COUNTY OFFICES. THE APPROVAL OF THIS PLAN BY THE WEBER COUNTY SURVEYOR DOES NOT RELIEVE THE LICENSED LAND SURVEYOR WHO EXECUTED THIS PLAN FROM THE RESPONSIBILITIES AND/OR LIABILITIES ASSOCIATED THEREWITH.  
 SIGNED THIS \_\_\_\_\_ DAY OF \_\_\_\_\_ 20\_\_\_\_  
 \_\_\_\_\_  
 SIGNATURE

**WEBER COUNTY ENGINEER**  
 I HEREBY CERTIFY THAT THE REQUIRED PUBLIC IMPROVEMENT STANDARDS AND DRAWINGS FOR THIS SUBDIVISION CONFORM WITH COUNTY STANDARDS AND THE AMOUNT OF THE FINANCIAL GUARANTEE IS SUFFICIENT FOR THE INSTALLATION OF THESE IMPROVEMENTS.  
 SIGNED THIS \_\_\_\_\_ DAY OF \_\_\_\_\_ 20\_\_\_\_  
 \_\_\_\_\_  
 SIGNATURE

**WEBER COUNTY ATTORNEY**  
 I HAVE EXAMINED THE FINANCIAL GUARANTEE AND OTHER DOCUMENTS ASSOCIATED WITH THIS SUBDIVISION PLAN AND IN MY OPINION THEY CONFORM WITH THE COUNTY ORDINANCE APPLICABLE THERETO AND NOW IN FORCE AND EFFECT.  
 SIGNED THIS \_\_\_\_\_ DAY OF \_\_\_\_\_ 20\_\_\_\_  
 \_\_\_\_\_  
 SIGNATURE

**WEBER-MORGAN HEALTH DEPARTMENT**  
 I HEREBY CERTIFY THAT THE SOILS, PERCOLATION RATES, AND SITE CONDITION FOR THIS SUBDIVISION HAVE BEEN INVESTIGATED BY THIS OFFICE AND ARE APPROVED FOR ON-SITE WASTEWATER DISPOSAL SYSTEMS.  
 SIGNED THIS \_\_\_\_\_ DAY OF \_\_\_\_\_ 20\_\_\_\_  
 \_\_\_\_\_  
 DIRECTOR, WEBER-MORGAN HEALTH DEPARTMENT

**WEBER COUNTY PLANNING COMMISSION APPROVAL**  
 THIS IS TO CERTIFY THAT THIS SUBDIVISION PLAN WAS DULY APPROVED BY THE WEBER COUNTY PLANNING COMMISSION ON THE \_\_\_\_\_ DAY OF \_\_\_\_\_ 20\_\_\_\_  
 \_\_\_\_\_  
 CHAIRMAN, WEBER COUNTY COMMISSION

**WEBER COUNTY COMMISSION ACCEPTANCE**  
 THIS IS TO CERTIFY THAT THIS SUBDIVISION PLAN, THE DEDICATION OF STREETS AND OTHER PUBLIC WAYS, AND FINANCIAL GUARANTEE OF PUBLIC IMPROVEMENTS ASSOCIATED WITH THIS SUBDIVISION, THEREIN ARE HEREBY APPROVED AND ACCEPTED BY THE COMMISSIONERS OF WEBER COUNTY, UTAH THIS \_\_\_\_\_ DAY OF \_\_\_\_\_ 20\_\_\_\_  
 \_\_\_\_\_  
 TITLE: CHAIRMAN, WEBER COUNTY COMMISSION  
 ATTEST:

NOTE:  
 NO BASEMENTS ALLOWED IN THIS DEVELOPMENT.

**AGRICULTURAL NOTE**  
 AGRICULTURE IS THE PREFERRED USE IN THE AGRICULTURE ZONES. AGRICULTURE OPERATIONS AS SPECIFIED IN THE ZONING ORDINANCE FOR A PARTICULAR ZONE ARE PERMITTED AT ANY TIME INCLUDING THE OPERATION OF FARM MACHINERY AND NO ALLOWED AGRICULTURE USE SHALL BE SUBJECT TO RESTRICTION ON THE BASIS THAT IT INTERFERES WITH ACTIVITIES OF FUTURE RESIDENTS OF THIS SUBDIVISION.

**SURVEYOR'S CERTIFICATE**  
 I, Tyler D. Knight, do hereby certify that I am a professional land surveyor in the State of Utah and hold certificate no. 9008384-2201 as prescribed by the laws of this State. That I have made a survey of the property(s) shown hereon in accordance with UCA 17-23-17. That this plan was prepared from the field notes of this survey and from documents and records as noted hereon. That all lots meet current lot width and area requirements for Weber County Zoning.

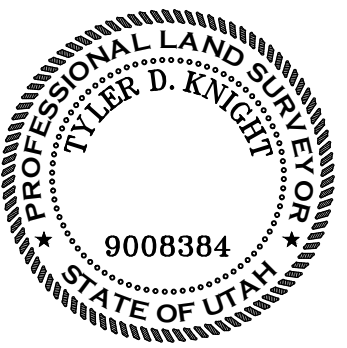

**NARRATIVE**  
 THE PURPOSE OF THIS SURVEY WAS TO DIVIDE THE COMMON AREA OF THE EXISTING CLUSTER SUBDIVISION INTO THREE (3) OPEN AREA PARCELS TO BE SOLD FOR INDIVIDUAL OWNERSHIP.  
 SURVEY'S USED TO AID IN THIS PLAN: STEVE WEST SUBDIVISION, HOLGATE SUBDIVISION AND HOLGATE SUBDIVISION - AMENDED LOT 4 AS FOUND IN THE WEBER COUNTY RECORDERS OFFICE.  
 JACQUELYN ESTATES CLUSTER SUBDIVISION PHASE 1, AS FOUND IN THE WEBER COUNTY RECORDERS OFFICE.  
 BASIS OF BEARING IS UTAH STATE PLANE BEARING AS SHOWN.

DEVELOPER:  
 CJ HOMES  
 PH: 801-540-4989

**LANDMARK SURVEYING, INC.**  
 A COMPLETE LANDSURVEYING SERVICE  
 4646 S. 3500 W. #A-3, WEST HAVEN, UTAH 84401  
 PHONE 801-731-4075 FAX 801-731-8506  
 LANDMARKSURVEYINGUTAH.COM

CLIENT: CRAIG STANDING PH 801-540-4989  
 LOCATION: A PART OF THE NORTHWEST 1/4 OF SECTION 29, T.6N., R.2W., S.L.B.&M. WEBER COUNTY, UTAH  
 SURVEYED: JAN 2014

REVISIONS:	DRAWN BY: TK
	CHECKED BY: TK
	DATE: OCT. 17, 2014
	FILE: 3010AMD1

**WEBER COUNTY RECORDER**  
 ENTRY # \_\_\_\_\_ FEE \_\_\_\_\_  
 FILED FOR RECORD & RECORDED  
 THIS \_\_\_\_\_ DAY OF \_\_\_\_\_ 20\_\_\_\_  
 AT \_\_\_\_\_ IN BOOK \_\_\_\_\_ OF \_\_\_\_\_  
 PAGE \_\_\_\_\_  
 \_\_\_\_\_  
 WEBER COUNTY RECORDER  
 BY \_\_\_\_\_ DEPUTY

BASIS OF BEARING STATE PLANE GRID BEARING PER WEBER COUNTY 2666.687 MEAS. 2666.674 REC.