

ROPER BUILDINGS

HARRIS BUILDING

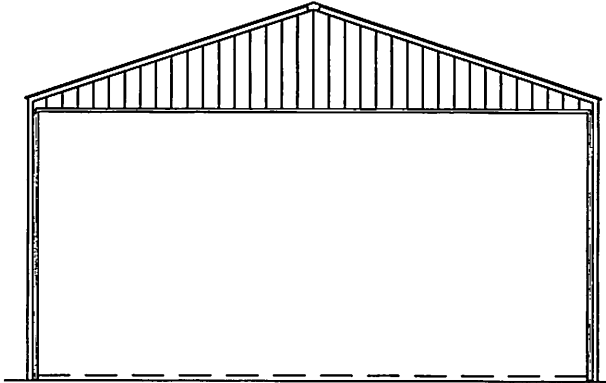

DESIGN CRITERIA AND NOTES

DESIGN CRITERIA
 DESIGN ACCORDING TO THE 2012 IBC.
 FOR SPECIFICATIONS NOT SHOWN REFER TO THE 2012 IBC.

DESIGN CATEGORY:
 RISK CATEGORY I - AGRICULTURAL/MINOR STORAGE

SEISMIC CRITERIA:
 DESIGN SPECTRAL RESPONSE SDS: 71%
 DESIGN CATEGORY D
 SOIL SITE CLASS D (ASSUMED)
 R = 6.5 (CORRUGATED STEEL SHEETED SHEAR WALLS)

WIND LOAD:
 ULTIMATE WIND DESIGN SPEED: 105 MPH 3 SEC. GUST
 TERRAIN EXPOSURE C
 PARTIALLY ENCLOSED

SNOW LOAD:
 ROOF DESIGN SNOW LOAD 40 PSF

DEAD LOADS:
 ROOF STRUCTURE 5 PSF
 WALLS 3 PSF

CONCRETE FOUNDATION NOTES

SIZE (MINIMUM):
 24" DIAMETER X 3'-0" DEEP
 SEE FOOTING PLAN.
 REINFORCEMENT: NO PIER REINFORCEMENT.

MIN. 28 DAY STRENGTH (F'C) W/ NORMAL 145 PCF DENSITY:
 FOOTINGS: 2500 PSI
 SLABS ON GRADE:
 2500 PSI REQUIRED, 3500 PSI RECOMMEND

ALL SLABS:
 PROVIDE A MIN. THICKNESS OF 4" W/ 4" DEEP MIN.
 CRUSHED GRAVEL BASE.
 PROVIDE 1" DEEP CONTRACTION / CONSTRUCTION JOINTS
 NO FURTHER THAN 10' APART IN ANY DIRECTION.

GENERAL

PLEASE REFER TO THE STRUCTURAL CALCULATIONS FOR ALL SPECIFICATIONS AND DESIGN CRITERIA NOT LISTED HERE. WHERE DETAILS ARE NOT SPECIFIED, TYPICAL DETAILS AS SPECIFIED ON PLANS AND ON THE STRUCTURAL DETAILS SHEET SHALL APPLY.

SOILS AND EXCAVATION

UNIFIED SOIL CLASSIFICATION: NO SOILS REPORT PROVIDED. STABLE SOIL CHARACTERISTICS ASSUMED.

ALLOWABLE BEARING PRESSURE: 1500 PSF

ALL DESIGN WAS BASED ON STABLE SOIL CHARACTERISTICS. GEOTECHNICAL HAZARDS FOUND ON OR AROUND THE SITE, INCLUDING EXPANSIVE CLAYS, OR SOILS FOUND AT THE SITE WHILE EXCAVATION OCCURS WHICH DIFFERS FROM THOSE ASSUMED SHOULD BE BROUGHT TO THE ATTENTION OF THE BUILDING OFFICIAL AND ENGINEER.

BUILDING INFORMATION

SITE INFORMATION:

ADDRESS:
 6502 E SUMMIT ROAD
 HUNTSVILLE, UT 84317

BUILDING INFORMATION:
 SQUARE FOOTAGE: 1296 S.F.
 DIMENSIONS: 36' x 36'

CONTACTS

CONTRACTOR:

ROPER BUILDINGS
 CONTACT: DAN SCARBROUGH
 PHONE: 801-540-5586

DRAFTING AND ENGINEERING:

WILDING ENGINEERING, INC.
 CONTACT: DEREK LLOYD
 PHONE: 801-553-8112



DRAWING INDEX

SHEET	DESCRIPTION
00	COVER SHEET
01	FOUNDATION PLAN
02	FLOOR PLAN
03	GIRT PLAN
04	ELEVATIONS
05	ROOF PLAN
06	PANEL LAYOUT
07	DETAIL SHEET
08	DETAIL SHEET

DATE

07/17/15

FOUNDATION PLAN

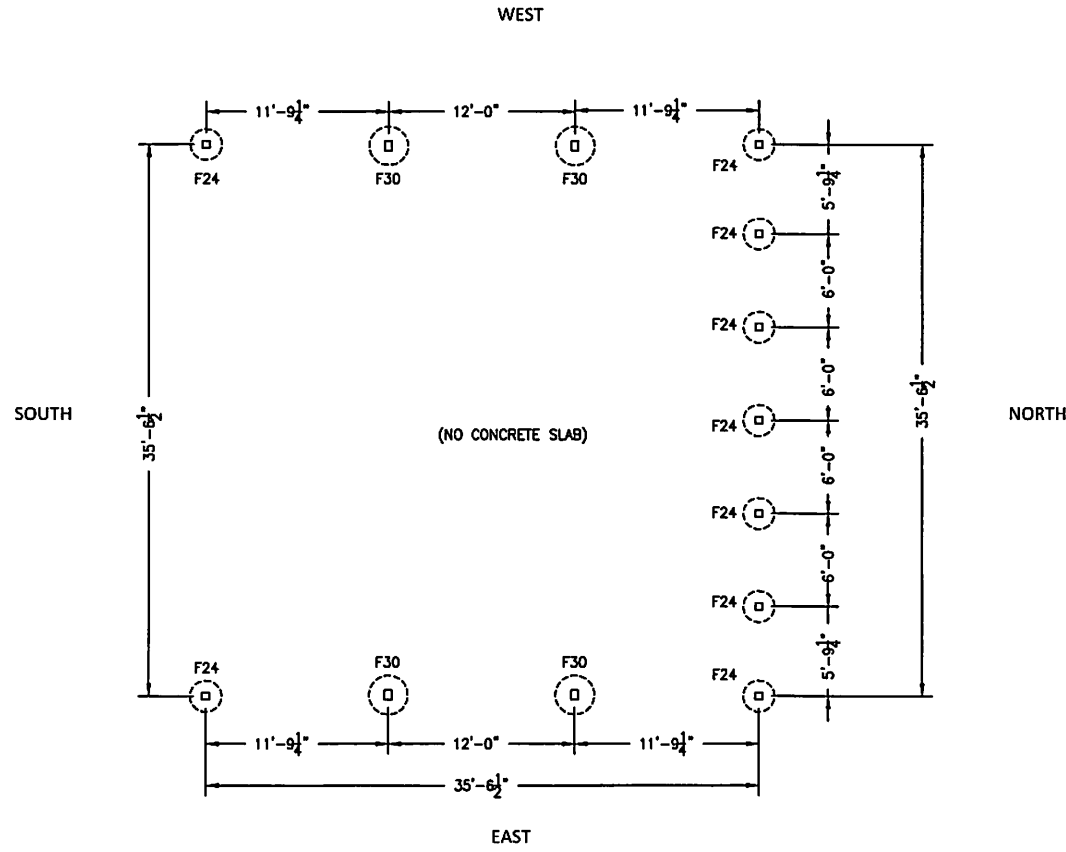

- PIERS:
1. F24: 24" DIA x 48" DEEP CONCRETE PIER
 2. F30: 30" DIA x 48" DEEP CONCRETE PIER

△	RELEASE TO CLIENT	07/17/15
NO.	REVISION	DATE

PROJECT INFORMATION	
HARRIS BUILDING	
FOUNDATION PLAN	
HUNTSVILLE, UTAH	

DRAWN	DATE
JDL	07/17/2015
CHECKED	SCALE
MEC	1/8" = 1'-0"
PROJECT #	SHEET
15109	01

FLOOR PLAN

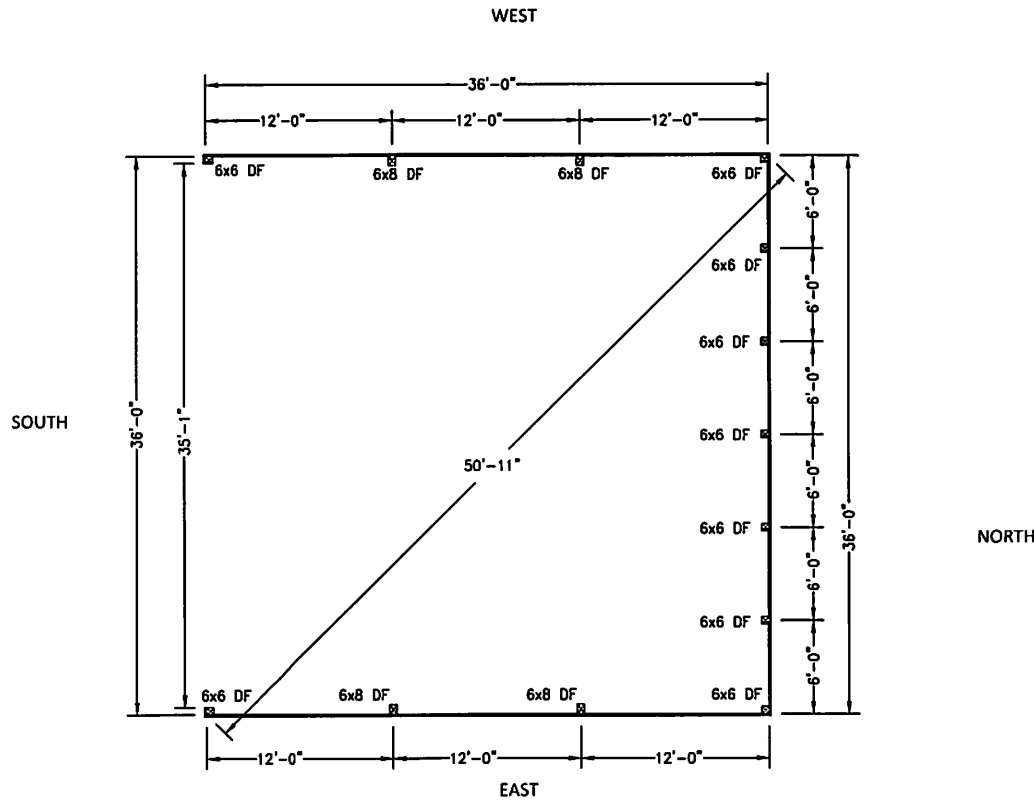

- NOTES:**
1. FLOOR AREA: 1,296 SQ FT
 2. 6X6 DF: 6X6 DF-L #2 TREATED POST. EMBED POST INTO CONCRETE PIER. SEE DETAIL ON SHEET 8.
 3. 6X8 DF: 6X8 DF-L #2 TREATED POST. EMBED POST INTO CONCRETE PIER. SEE DETAIL ON SHEET 8.

△	RELEASE TO CLIENT	07/17/15
NO.	REVISION	DATE

PROJECT INFORMATION	
HARRIS BUILDING	
FLOOR PLAN	
HUNTSVILLE, UTAH	

DRAWN	DATE
JDL	07/17/2015
CHECKED	SCALE
MEC	1/8" = 1'-0"
PROJECT #	SHEET
15109	02

GIRT PLAN

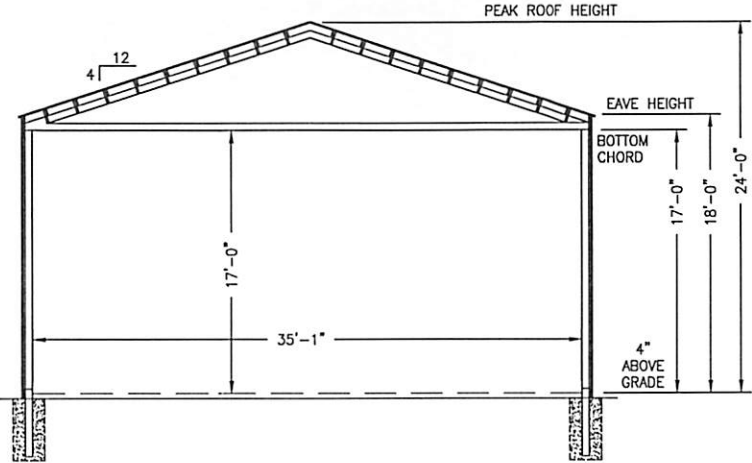

GABLE END GIRT WALL - SOUTH

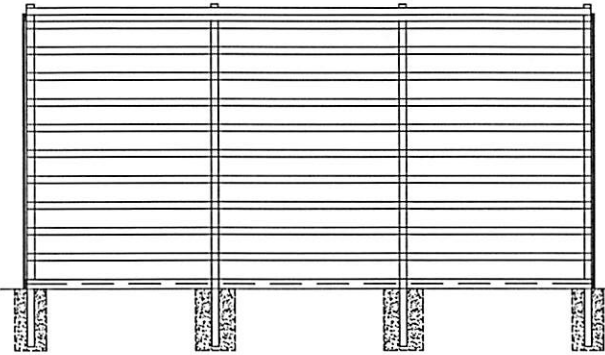

SIDE GIRT WALL - EAST

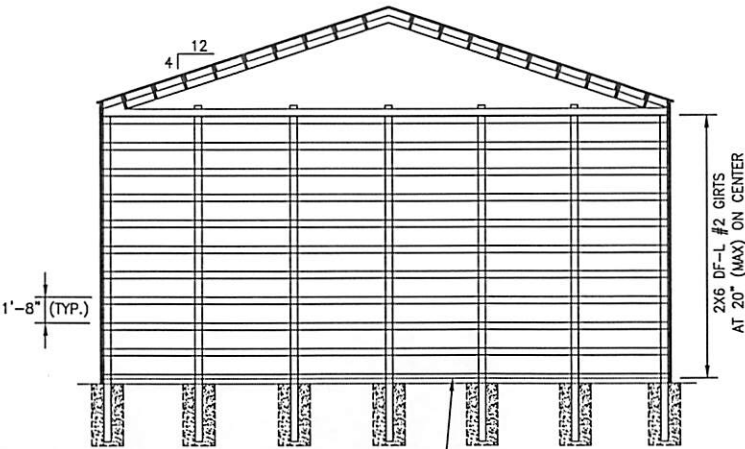

CENTER OF 2x8 SKIRT - GABLE END GIRT WALL - NORTH

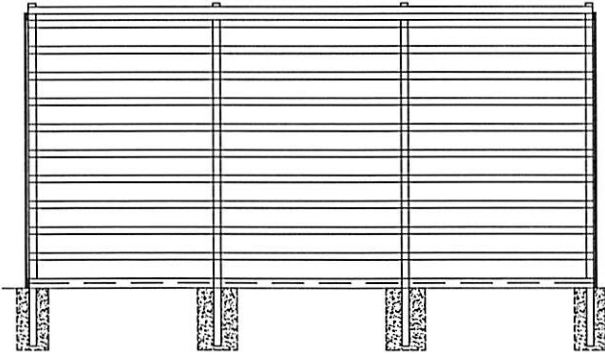

SIDE GIRT WALL - WEST

△	RELEASE TO CLIENT	07/17/15
NO.	REVISION	DATE

PROJECT INFORMATION	
HARRIS BUILDING	
GIRT PLAN	
HUNTSVILLE, UTAH	

DRAWN	JDL	DATE	07/17/2015
CHECKED	MEC	SCALE	1/8" = 1'-0"
PROJECT #	15109	SHEET	03

ELEVATIONS

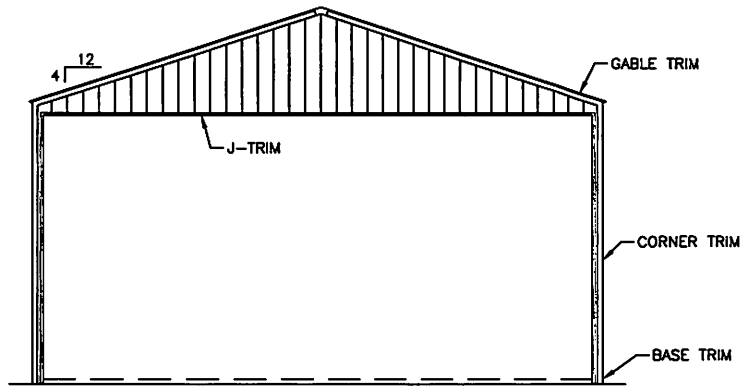

GABLE END ELEVATION - SOUTH

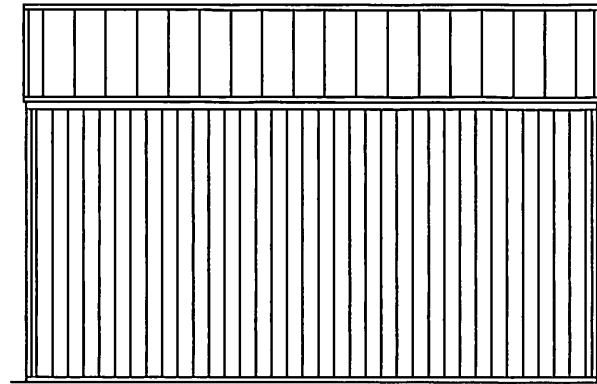

EAST ELEVATION

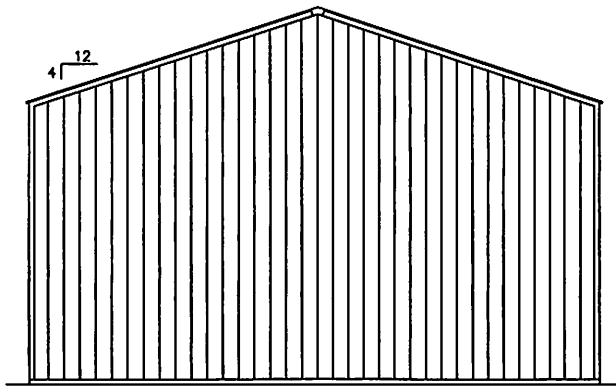

GABLE END ELEVATION - NORTH

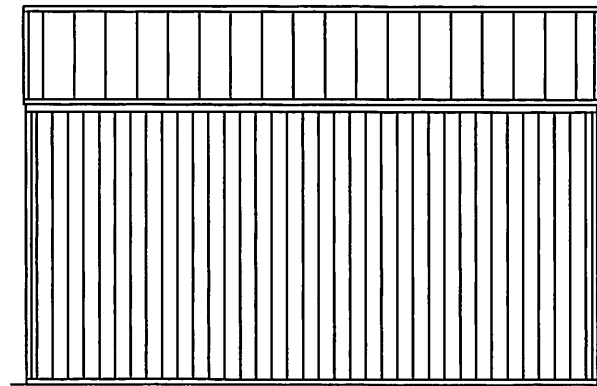

WEST ELEVATION

△	RELEASE TO CLIENT	07/17/15
NO.	REVISION	DATE

PROJECT INFORMATION	
HARRIS BUILDING	
ELEVATIONS	
HUNTSVILLE, UTAH	

DRAWN	JDL	DATE	07/17/2015
CHECKED	MEC	SCALE	1/8" = 1'-0"
PROJECT #	15109	SHEET	04

ROOF PLAN

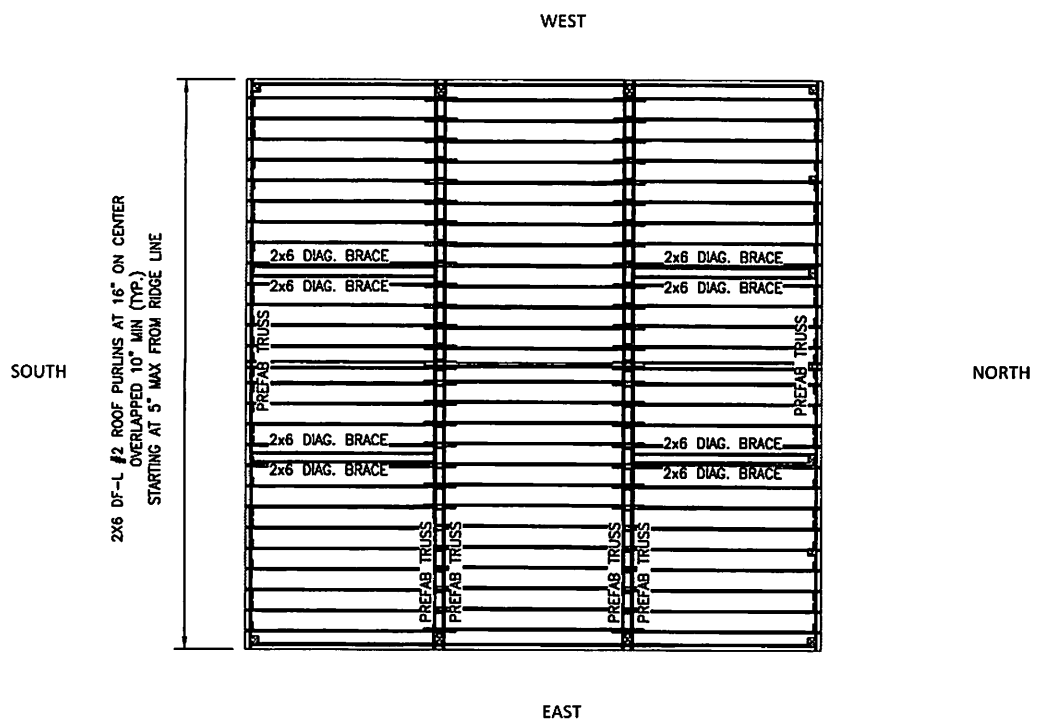

2x6 DF-L #2 ROOF PURLINS AT 16" ON CENTER
 OVERLAPPED 10" MIN (TYP.)
 STARTING AT 5" MAX FROM RIDGE LINE

△	RELEASE TO CLIENT	07/17/15
NO.	REVISION	DATE

PROJECT INFORMATION
HARRIS BUILDING
ROOF PLAN
HUNTSVILLE, UTAH

DRAWN JDL	DATE 07/17/2015
CHECKED MEC	SCALE 1/8" = 1'-0"
PROJECT # 15109	SHEET 05

PANEL LAYOUT

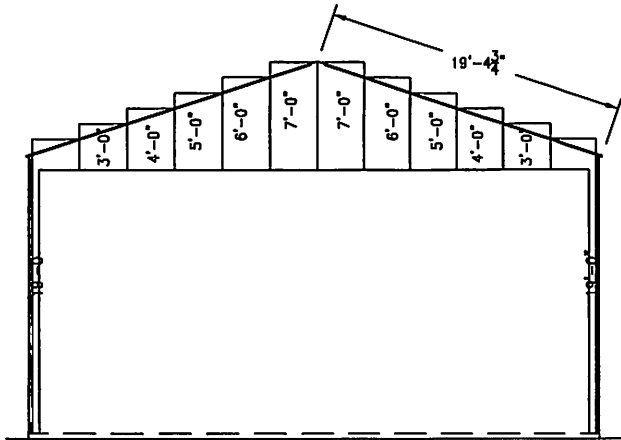

END PANEL LAYOUT - SOUTH

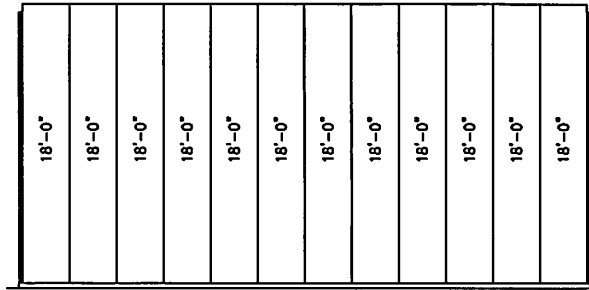

SIDE PANEL LAYOUT - EAST

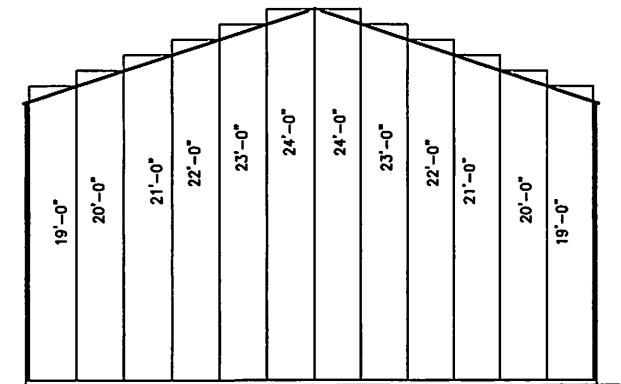

END PANEL LAYOUT - NORTH

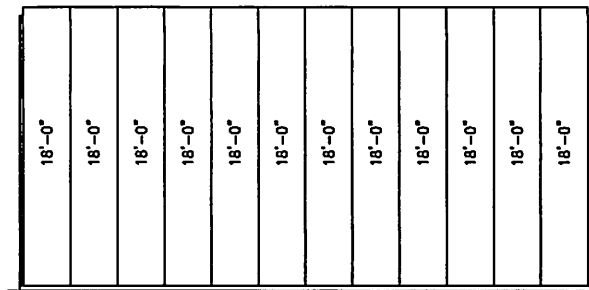

SIDE PANEL LAYOUT - WEST

△	RELEASE TO CLIENT	07/17/15
NO.	REVISION	DATE

PROJECT INFORMATION	
HARRIS BUILDING	
PANEL LAYOUT	
HUNTSVILLE, UTAH	

DRAWN	DATE
JDL	07/17/2015
CHECKED	SCALE
MEC	1/8" = 1'-0"
PROJECT #	SHEET
15109	06

DETAIL SHEET

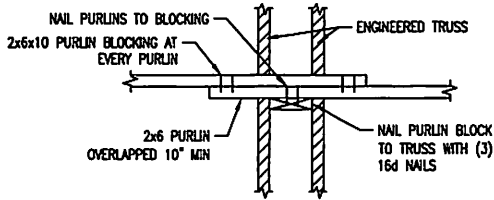

PURLIN CONNECTION
NOT TO SCALE

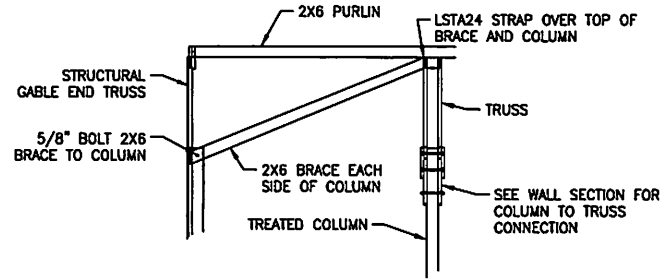

COLUMN TO TRUSS BRACE
NOT TO SCALE

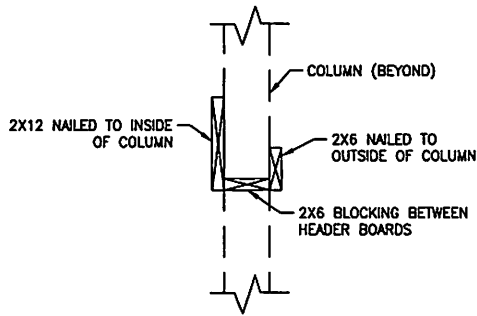

OVERHEAD DOOR HEADER
NOT TO SCALE

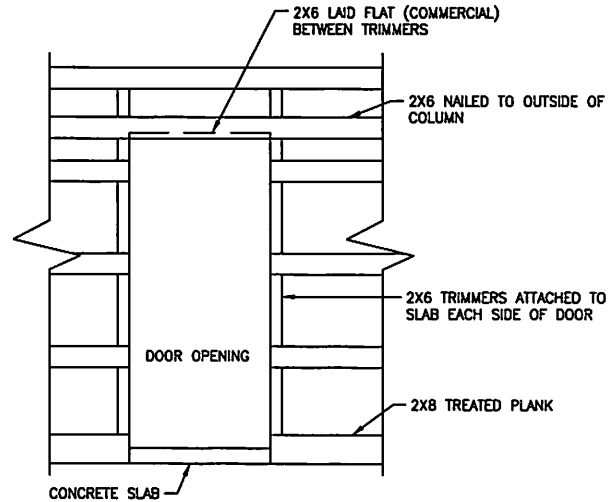

MAN DOOR OPENING
NOT TO SCALE

△	RELEASE TO CLIENT	07/17/15
NO.	REVISION	DATE

PROJECT INFORMATION	
HARRIS BUILDING	
DETAIL SHEET	
HUNTSVILLE, UTAH	

DRAWN	JDL	DATE	07/17/2015
CHECKED	MEC	SCALE	1/8" = 1'-0"
PROJECT #	15109	SHEET	07

DETAIL SHEET

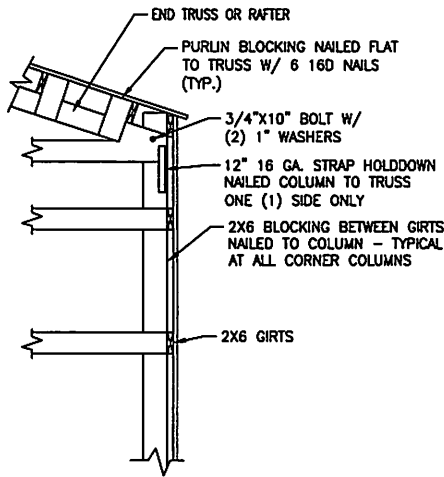

CORNER BLOCKING
NOT TO SCALE

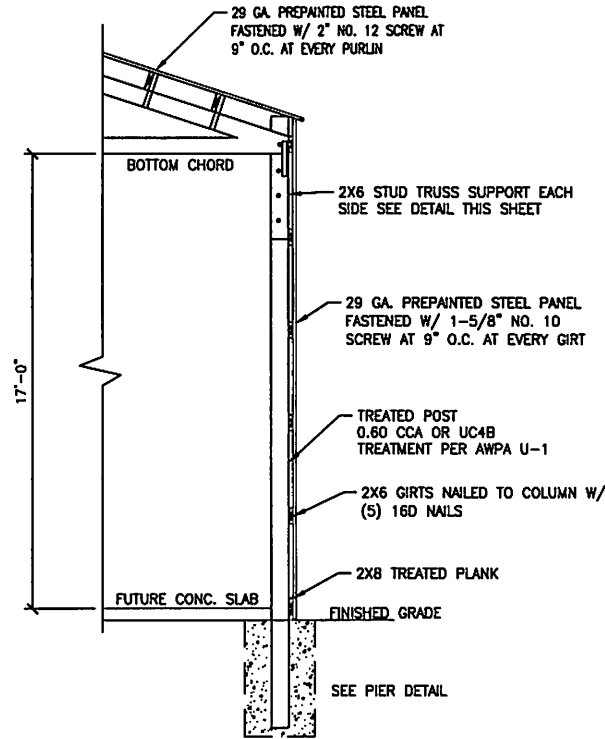

TYPICAL WALL SECTION
NOT TO SCALE

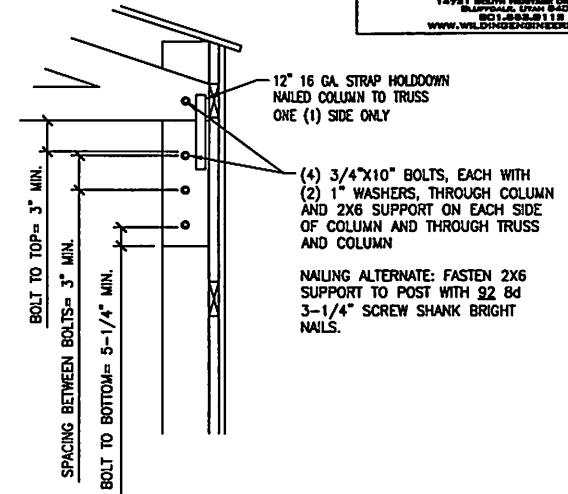

TRUSS SUPPORT TO POST CONNECTION DETAIL
NOT TO SCALE

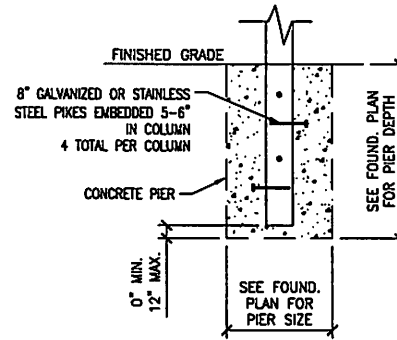

PIER DETAIL
NOT TO SCALE

△	RELEASE TO CLIENT	07/17/15
NO.	REVISION	DATE

PROJECT INFORMATION	
HARRIS BUILDING	
DETAIL SHEET	
HUNTSVILLE, UTAH	

DRAWN JDL	DATE 07/17/2015
CHECKED MEC	SCALE 1/8" = 1'-0"
PROJECT # 15109	SHEET 08