

BIG SKY ESTATES NO. 1 - LOT 23 2ND AMENDMENT

A PART OF THE WEST 1/2 OF SEC. 33 T.7N., R.1E., S.L.B.&M.

WEBER COUNTY, UTAH

JULY 2015

OWNER'S DEDICATION

We the undersigned owners of the herein described tract of land, do hereby set apart and subdivide the same into lots and streets as shown hereon and name said tract BIG SKY ESTATES NO. 1 - LOT 23 2ND AMENDMENT and do hereby dedicate to public use all those parts or portions of said tract of land designated as streets, the same to be used as public thoroughfares forever, also grant and dedicate a perpetual right and easement over, upon and under the lands designated hereon as public utility, storm water detention ponds drainage easements, the same to be used for the installation, maintenance and operation of public utility service line, storm drainage facilities or for the perpetual preservation of water channels in their natural state whichever is applicable as may be authorized by the governing authority, with no buildings or structures being erected within such easements.

Signed this _____ day of _____, 20__.

Karl Lundin _____

ACKNOWLEDGMENT

State of Utah)
County of Weber)ss

On this ____ day of _____, 20__, personally appeared before me, the undersigned notary public, the signers of the above owners dedication _____ in number, who duly acknowledged to me that they signed it freely and voluntarily and for the purposes therein mentioned.

Commission Expires _____ Notary Public _____

BOUNDARY DESCRIPTION

All of Lot 23, Big Sky Estates No. 1, Weber County, Utah, according to the official plat thereof.

More particularly described as follows:
Part of the West 1/2 of Section 33, Township 7 North, Range 1 East, Salt Lake Base & Meridian, U.S. Survey.
Beginning at the Southwest corner of Lot 22 of said Big Sky Estates No. 1 which is South 0°32'24" West 2661.10 Feet along the Section line and South 89°56'36" East 892.39 Feet from the Northwest corner of said Section 33; and running thence South 79°53'16" East along the South line of said Lot 22 407.71 Feet to the Easterly boundary of said subdivision; thence South 25°06'44" West along said Easterly boundary 163.38 Feet to the Northeast corner of Lot 24 of said subdivision; thence North 79°53'16" West along the North line of said Lot 24 444.33 Feet to the Easterly right of way of Panorama Circle; thence the following two (2) courses along said right of way: Northerly along the arc of a 81.59 foot radius curve to the right a distance of 26.84 feet (Delta is 18°50'55" and Chord Bears North 28°39'49" East 26.72 Feet) and North 38°06'00" East 150.03 Feet to the point of beginning.

SURVEYOR'S CERTIFICATE

I, Tyler D. Knight, holding license number 9008384-2201 in accordance with Title 58, Chapter 22, Professional Engineers and Land Surveyors Licensing Act, have completed a survey of the property described on the plat in accordance with Section 17-23-17 and have verified all measurements and placed monuments as represented on the plat.

I do also hereby certify that this plat of BIG SKY ESTATES NO. 1 - LOT 23 2ND AMENDMENT in Weber County, Utah, has been correctly drawn to scale and is a true and correct representation of the following description of lands included in said subdivision, based on data compiled from records in the Weber County Records Office, Weber County Surveyors Office and of a survey made on the ground.

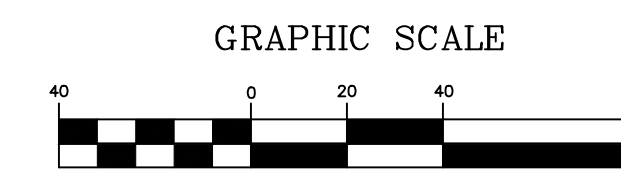
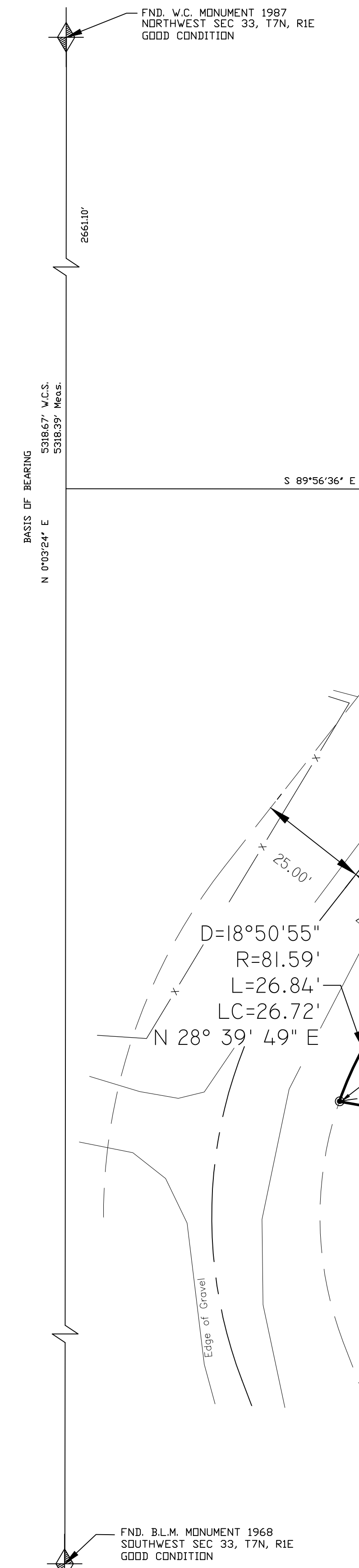

- - - - - EXISTING FENCE
- - - - - EASEMENT LINE
- - - - - ADJACENT BOUNDARIES
- SET 5/8" x 24" REBAR WITH CAP STAMPED 167594
- FOUND REBAR & CAP

WEBER-MORGAN HEALTH DEPARTMENT

I hereby certify that the soils, percolation rates, and site condition for this subdivision have been investigated by this office and are approved for on-site wastewater disposal systems.

Signed this _____ day of _____, 20__.

Director, Weber-Morgan Health Department.

PERC TABLE

PERC TEST HOLE	DEPTH, IN.	SOILS EVALUATION
1	0" - 18"	LOAM, GRANULAR STRUCTURE, HIGH ORGANIC
	18" - 33"	GRAVELLY SILTY CLAY LOAM, MASSIVE STRUCTURE
2	0" - 14"	LOAM, GRANULAR STRUCTURE, HIGH ORGANIC
	14" - 58"	SILTY LOAM, MASSIVE STRUCTURE
	58" - 67"	SILTY CLAY LOAM

WEBER COUNTY SURVEYOR

I hereby certify that the Weber County Surveyor's office has reviewed this plat for mathematical correctness, Section Corner data, and for harmony with lines and monuments on record in County offices. The approval of this plat by the Weber County Surveyor does not relieve the licensed Land Surveyor who executed this plat from the responsibilities and/or liabilities associated therewith.

Signed this _____ day of _____, 20__.

Signature _____

WEBER COUNTY ATTORNEY

I have examined the financial guarantee and other documents associated with this subdivision plat and in my opinion they conform with the County Ordinance applicable thereto and now in Force and effect.

Signed this _____ day of _____, 20__.

Signature _____

WEBER COUNTY COMMISSION ACCEPTANCE

This is to certify that this subdivision plat, the dedication of streets and other public ways and financial guarantee of public improvements associated with this subdivision thereon are hereby approved and accepted by the Commissioners of Weber County, Utah this _____ day of _____, 20__.

Title: Chairman, Weber County Commission

Attest _____

Title _____

Note:

The 20' Drainage Easement for this lot as shown on BIG SKY ESTATES NO. 1, Weber County, Utah, Book 15, Page 14 & 15, is vacated per UCA 17-27a-609.

This Lot is designated with the letter 'R' and shall be subject to the provisions of Chapter 36-B of the Zoning Ordinance prior to any construction or building being undertaken upon such lot.

WEBER COUNTY PLANNING COMMISSION APPROVAL

This is to certify that this subdivision plat was duly approved by the Weber County Planning Commission on the _____ day of _____, 20__.

Signature _____

WEBER COUNTY ENGINEER

I hereby certify that the required public improvement standards and drawings for this subdivision conform with county standards and the amount of the financial guarantee is sufficient for the installation of these improvements.

Signed this _____ day of _____, 20__.

Signature _____

NARRATIVE

The purpose of this survey was to amend Lot 23, Big Sky Estates No. 1 and the Drainage Easement from the original plat to run parallel to the Southerly boundary of said Lot 23.

Property corners were found or identified as shown on this plat. Bearings from the original plat have been rotated to match Weber County bearings per the Weber County Surveyors Office.

Basis of Bearing is as shown and is State Plane Grid Bearing.

<p>LANDMARK SURVEYING, INC. A COMPLETE LAND SURVEYING SERVICE 4646 S. 3500 V. RD-3, WEST HAVEN, UTAH 84401 PHONE: 801-791-4073 www.landmarksurveying.com</p>	<p>WEBER COUNTY RECORDER</p>	
	<p>CLIENT/DEVELOPER: Karl Lundin 801-791-6262</p>	<p>ENTRY # _____ FEE _____</p>
<p>LOCATION: 2292 Panorama Circle, Liberty, UT 84310 W 1/2 SEC 33, T.7N., R.1E., S.L.B.&M.</p>	<p>FILED FOR RECORD & RECORDED THIS _____ DAY OF _____ 20__</p>	
<p>SURVEYED: Oct. 2013</p>	<p>AT _____ IN BOOK _____ OF _____ PAGE _____</p>	
<p>REVISIONS: _____</p>	<p>DRAWN BY: TK</p>	<p>WEBER COUNTY RECORDER</p>
	<p>CHECKED BY: DKB</p>	<p>BY _____</p>
	<p>DATE: 7-31-15</p>	<p>DEPUTY</p>
	<p>FILE: 3359</p>	