

Reeve & Associates, Inc.
 920 CHAMBERS STREET, SUITE 14, OGDEN, UTAH 84403
 TEL: (801) 621-3100 FAX: (801) 621-2666 www.reeve-assoc.com
 LAND PLANNERS • CIVIL ENGINEERS • LAND SURVEYORS
 TRAFFIC ENGINEERS • STRUCTURAL ENGINEERS • LANDSCAPE ARCHITECTS

REVISIONS	DATE	DESCRIPTION
9-3-14	RH	Client Changes
1-12-15	RH	County Comments
1-20-15	RH	County Comments
2-11-15	RH	Client Changes
3-17-15	TP	County Comments

- Construction Notes:**
- ALL CONSTRUCTION IS TO CONFORM TO THE STANDARD DRAWINGS AND SPECIFICATIONS OF WEBER COUNTY.
- CULINARY WATER**
 W/10 - 10" PVC C-900 CLASS 200 WATER
- STORM DRAIN**
 SD/15 - 15" RCP STORM DRAIN
 SD/15 ARCH - 15" ARCH RCP STORM DRAIN
- SANITARY SEWER**
 SS/8 - 8" PVC C-900 SEWER LINE
 SS/12 - 12" PVC C-900 SEWER LINE
- SECONDARY WATER**
 SW/8 - 8" PVC C-900 SECONDARY WATER LINE
- LAND DRAIN**
 LD/8 - 8" PERFORATED PVC C-900 LAND DRAIN WRAPPED IN FABRIC

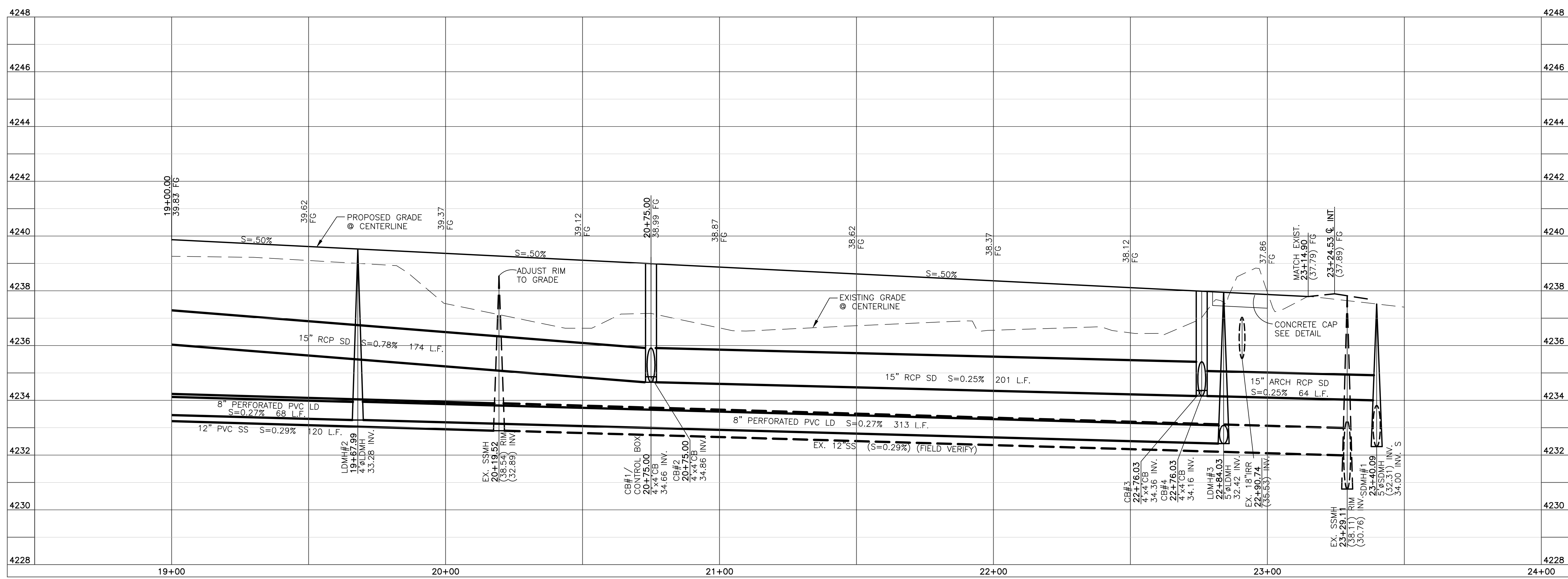
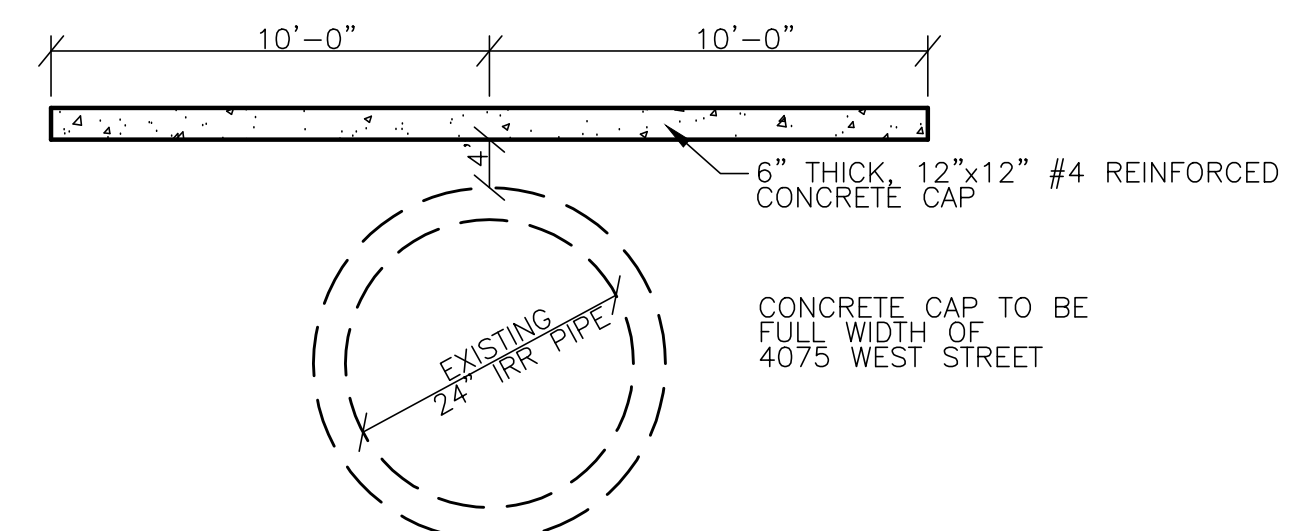
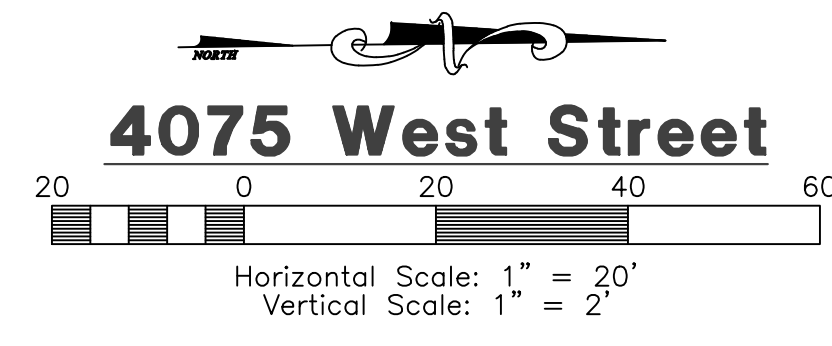
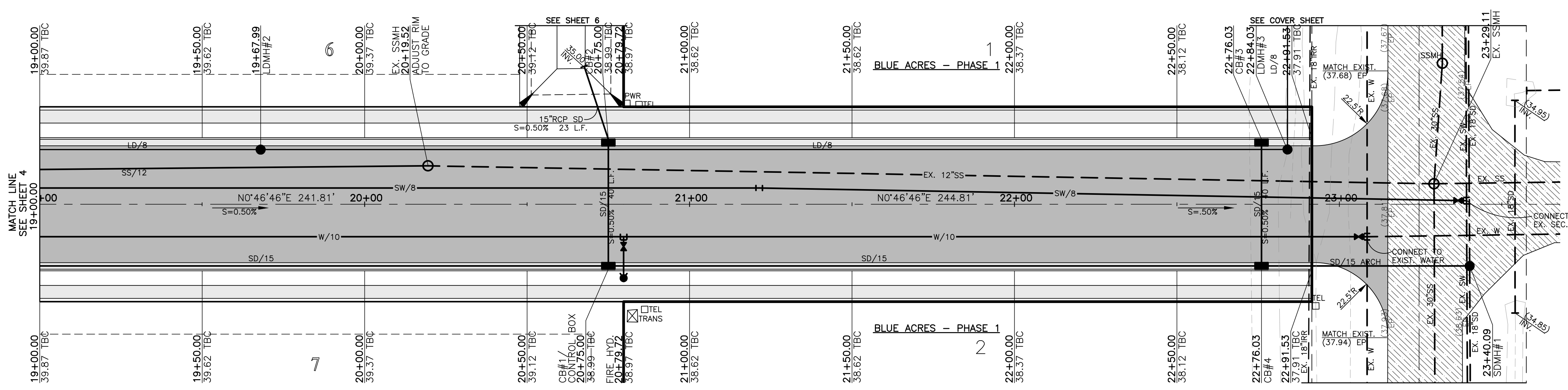

Blue Stakes Location Center
Call: Toll Free 1-800-662-4111
 Two Working Days Before You Dig

Revised: 3-17-15

Blue Acres Subdivision Phase-4
 WEBER COUNTY, UTAH
4075 West Street
19+00.00 - 23+50.00



Project Info.
 Engineer: J. NATE REEVE, P.E.
 Drafter: R. HANSEN
 Begin Date: JUNE 10, 2014
 Name: BLUE ACRES SUBDIVISION PHASE-4
 Number: 5036-01

Sheet **3** of **8** Sheets