

Reeve & Associates, Inc.
920 CHAMBERS STREET, SUITE 14, OGDEN, UTAH 84403
TEL: (801) 621-3100 FAX: (801) 621-2666 www.reeve-assoc.com
LAND PLANNERS • CIVIL ENGINEERS • LAND SURVEYORS
TRAFFIC ENGINEERS • STRUCTURAL ENGINEERS • LANDSCAPE ARCHITECTS



REVISIONS	DATE	DESCRIPTION
2	11-15-15	RH Client Changes
3	17-15-15	TP County Comments
3	27-15-15	TP County Comments
6	25-15-15	RH County Comments
7	22-15-15	RH County Comments
9	17-15-15	RH County Comments
11	12-15-15	RH County Comments

Construction Notes:

1) ALL CONSTRUCTION IS TO CONFORM TO THE STANDARD DRAWINGS AND SPECIFICATIONS OF WEBER COUNTY.

CULINARY WATER
W/10 - 10" PVC C-900 CLASS 200 WATER

STORM DRAIN
SD/15 - 15" RCP STORM DRAIN
SD/15 ARCH - 15" ARCH RCP STORM DRAIN

SANITARY SEWER
SS/8 - 8" PVC C-900 SEWER LINE
SS/12 - 12" PVC C-900 SEWER LINE

SECONDARY WATER
SW/8 - 8" PVC C-900 SECONDARY WATER LINE

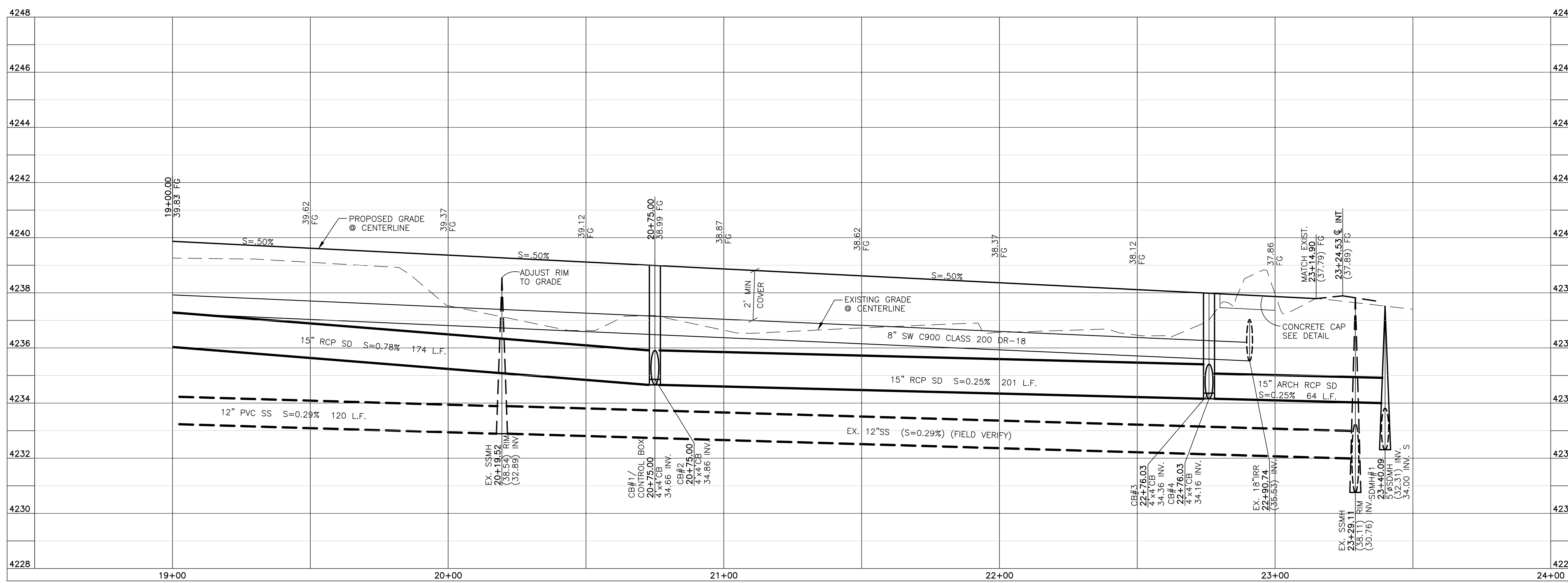
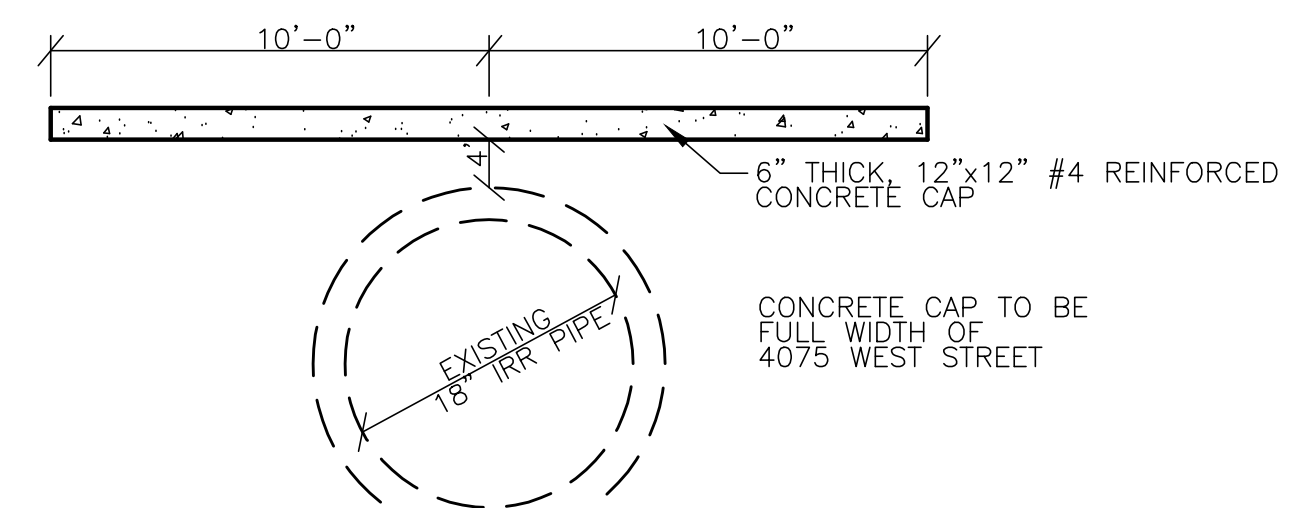
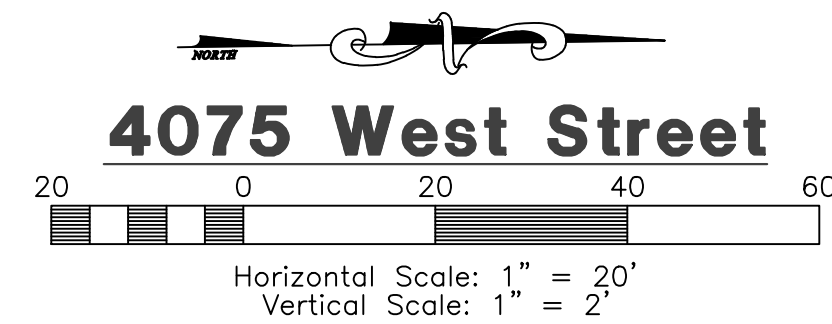
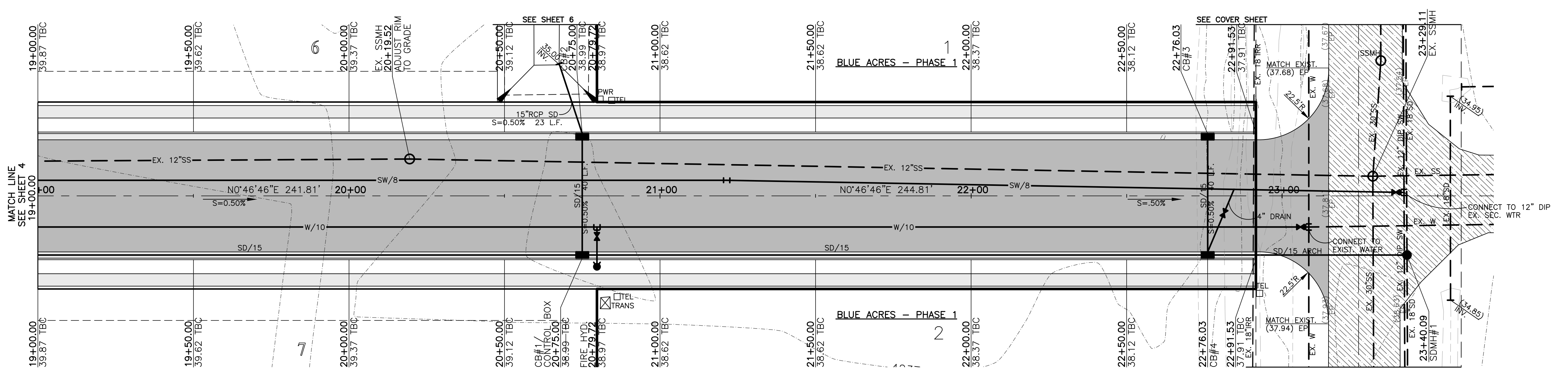

Blue Stakes Location Center
Call: Toll Free 1-800-662-4111
Two Working Days Before You Dig

Revised: 11-12-15

Blue Acres Subdivision Phase-4
WEBER COUNTY, UTAH
4075 West Street
19+00.00 - 23+50.00

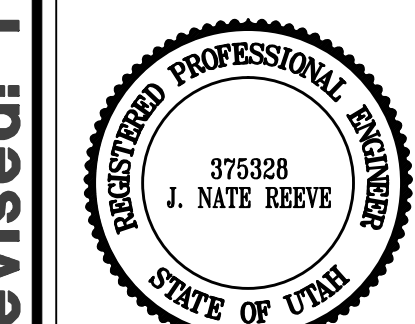

Project Info.
Engineer: J. NATE REEVE, P.E.
Drafted: R. HANSEN
Begin Date: JUNE 10, 2014
Name: BLUE ACRES SUBDIVISION PHASE-4
Number: 5036-01

Sheet **3** of **8** Sheets