

Line Table

LINE #	BEARING	DISTANCE
L1	N00°46'46"E	50.60
L2	N54°14'59"E	37.33
L3	N54°14'59"E	37.33
L4	N48°48'30"E	12.44

Curve Table

#	RADIUS	ARC LENGTH	CHD. LENGTH	TANGENT	CHD. BEARING	DELTA
C1	4062.12'	485.98'	485.68'	243.28'	N50°24'08"E	6°51'17"
C2	4062.12'	67.80'	67.80'	33.90'	S53°21'05"W	0°57'23"
C3	4062.12'	365.18'	365.06'	182.21'	N50°17'52"E	5°09'03"

Legend

- = SECTION CORNER
- = PUBLIC UTILITY EASEMENT
- = BOUNDARY LINE
- = LOT LINE
- = ADJOINING PROPERTY
- = EASEMENTS
- = SECTION TIE LINE
- = PROPOSED SANITARY SEWER LINE
- = EXISTING SANITARY SEWER LINE
- = PROPOSED IRRIGATION WATER LINE
- = EXISTING IRRIGATION WATER LINE (SIZE VARIES)
- = PROPOSED CULINARY WATER LINE (SIZE VARIES)
- = EXISTING CULINARY WATER LINE (SIZE VARIES)
- = PROPOSED STORM DRAIN (SIZE VARIES)
- = EXISTING STORM DRAIN
- = EXISTING FENCE LINE
- = PROPOSED FIRE HYDRANT
- = PROPOSED SANITARY SEWER MANHOLE
- = PLUG W/ 2" BLOW-OFF
- = PLUG & BLOCK
- = EXISTING ASPHALT SURFACE
- = PROPOSED ASPHALT SURFACE

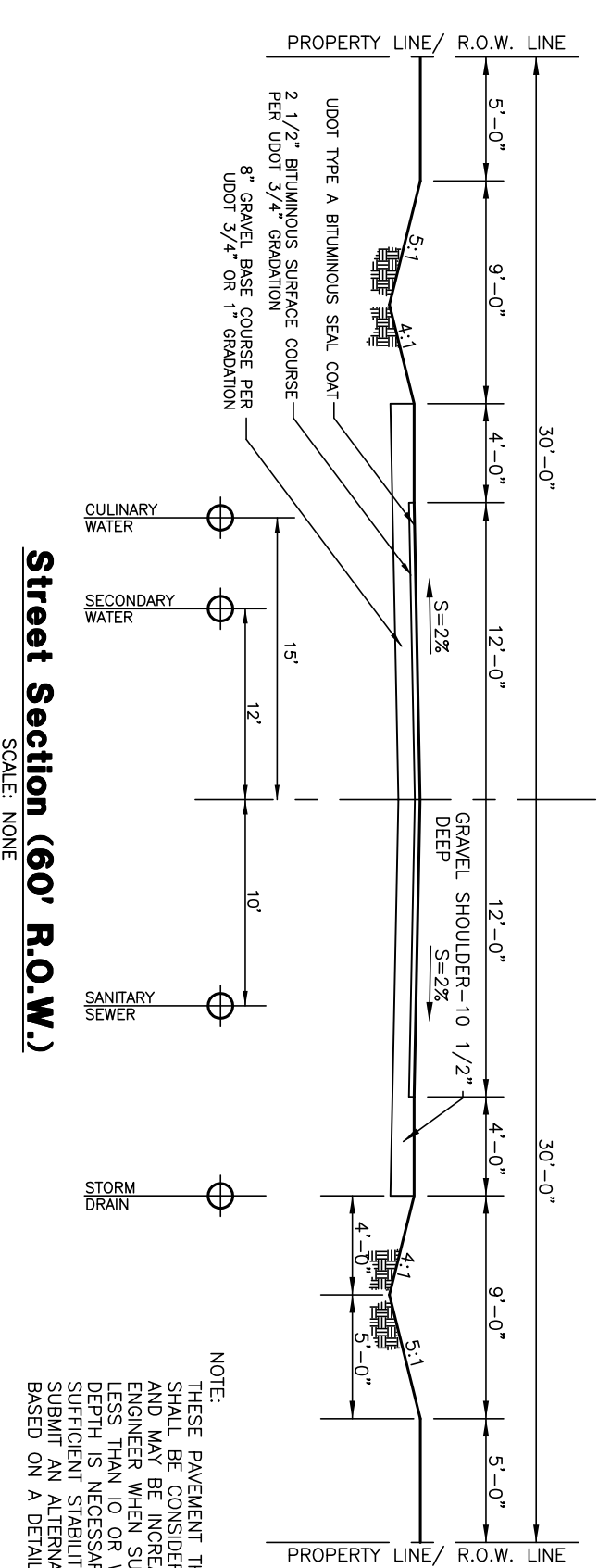
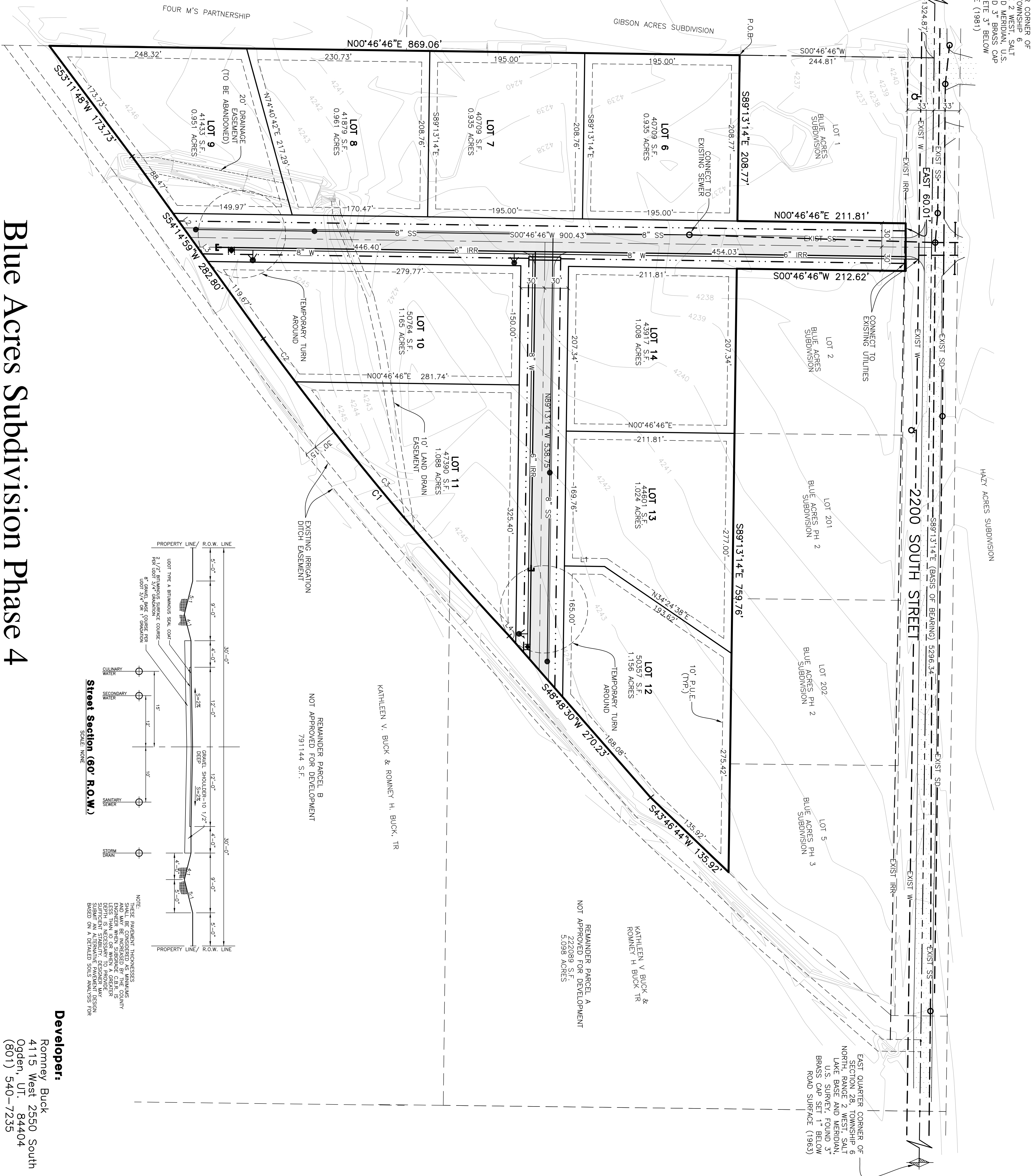

NOTE:
THESE PAYMENT THICKNESSES AND MAY BE INCREASED BY THE COUNTY ENGINEER TO A MINIMUM OF 1/2" OR MORE, OR WHEN A GREATER DEPTH IS NECESSARY TO PROVIDE SUFFICIENT STRENGTH TO SUPPORT TRAFFIC LOADS. THE DESIGNER SHALL SUBMIT AN ALTERNATIVE PAYMENT DESIGN BASED ON A DETAILED SOILS ANALYSIS FOR

Blue Acres Subdivision Phase 4

Weber County, Utah

Developer:
Romney Buck
4115 West 2550 South
Ogden, UT 84404
(801) 540-7235

Blue Acres Subdivision Phase 4
PART OF THE SW 1/4 OF SECTION 28, T.6N., R.2W., S.L.B & M., U.S. SURVEY
WEBER COUNTY, UTAH

Preliminary Plan

REVISIONS

DATE	DESCRIPTION

Reeve & Associates, Inc.
920 CHAMBERS STREET, SUITE 14, OGDEN, UTAH 84403
TEL: (801) 621-3100 FAX: (801) 621-2666 www.reeve-associ.com
LAND PLANNERS * CIVIL ENGINEERS * LAND SURVEYORS
TRAFFIC ENGINEERS * STRUCTURAL ENGINEERS * LANDSCAPE ARCHITECTS

Project Info.

Engineer: N. Reeve
Designer: C. Cove
Begin Date: AUGUST 27, 2014
Name: BLUE ACRES
SUBDIVISION PHASE 4
Number: 5036-01

Sheet **1** of **1** Sheets

NOTES:
1. CONTOURS ARE SHOWN WITH A ONE FOOT INTERVAL.
THESE PLANS AND SPECIFICATIONS ARE THE PROPERTY OF REEVE & ASSOCIATES, INC., 920 CHAMBERS STREET, SUITE 14, OGDEN, UTAH 84403, AND SHALL NOT BE REPRODUCED, RE-DRAWN, OR USED ON ANY PROJECT OTHER THAN THE PROJECT SPECIFICALLY DESIGNED FOR WITHOUT THEIR WRITTEN PERMISSION. THE OWNERS AND ENGINEERS OF REEVE & ASSOCIATES, INC. DISCLAIM ANY LIABILITY FOR ANY CHANGES OR MODIFICATIONS MADE TO THESE PLANS OR THE DESIGN THEREON WITHOUT THEIR CONSENT.