

2150 NORTH STREET

INDUSTRIAL AREA WITH NO PUBLIC SIDEWALKS

EMPLOYEE PARKING WITH ADA STALLS

PUBLIC PARKING WITH ADA STALLS

SECURITY OFFICE

EXISTING ADA ACCESS INTO FACILITY

6' HIGH SECURITY FENCE

RULON WHITE BLVD.

6' HIGH SECURITY FENCED CAMPUS FACILITY

PROPOSED WAREHOUSE FACILITY

NO PUBLIC ACCESS

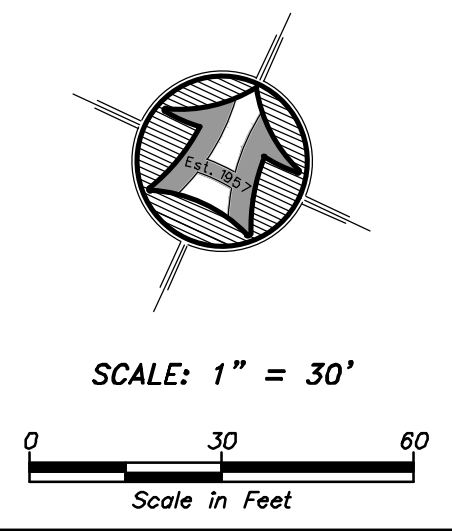

OVERALL CAMPUS FACILITY & PUBLIC ADA ACCESS FOR

KCC STORES WAREHOUSE

2150 N. Rulon White Blvd.
Farr West, Weber County, Utah

Sheet
C-100

Drawn By: MBJ Date: 11/04/24
 Checked By: _____
 Approved By: _____
 Scale: 1" = 30'
 Drawing File: 24-5-9 123.DWG
 JOB NUMBER: 24-5-9

HANSEN & ASSOCIATES, INC.
 Consulting Engineers and Land Surveyors
 538 North Main Street, Brigham, Utah 84302
 Visit us at www.hansen.net
 WEBER COUNTY Ogden (435) 399-4605 (435) 752-8272
 Celebrating 60 Years of Business

HA

PROFESSIONAL ENGINEER AND LAND SURVEYOR
 JAMES B. HANSEN
 No. _____ Date _____
 By _____
 Revision _____